

# INSTALLATION INSTRUCTIONS

# **EGR ROLLTRAC**

## ELECTRIC

**Vehicle Model: JEEP GLADIATOR (LH DRIVE)**  
**Year of manufacture: 2020 onwards**

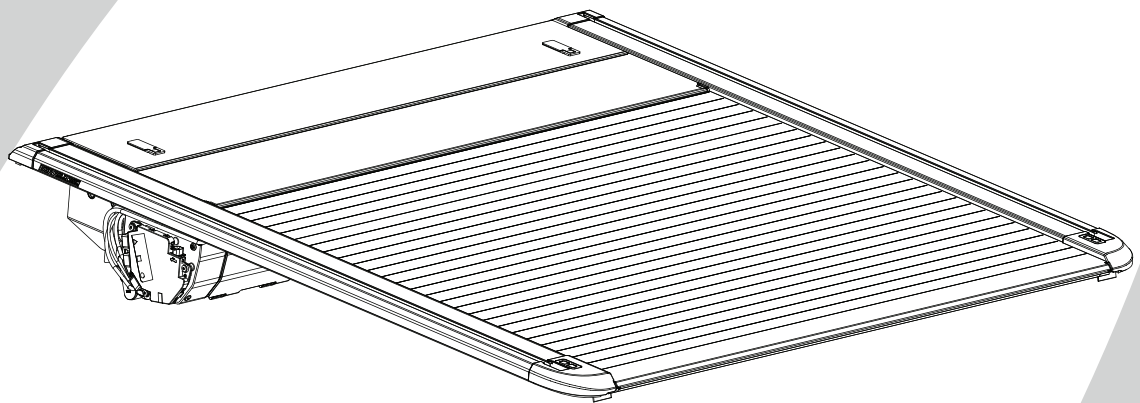

Installation time: 180 minutes

### Caution

- Do not attach EGR RollTrac in a location or by a method not specified.
- Do not use this product for any vehicle make or model, other than those specified in this document.
- Do not remove the plaque or label from this product.
- Do not modify the structure of the EGR RollTrac in any way.

### General Notes

- Read through the fitting instructions before installation of EGR RollTrac.
- Always install the accessory following the fitting instructions. Failure to do so may cause damage to the vehicle or the accessory.
- Ensure all recyclable discarded vehicle accessory components and packaging are recycled following local recycling regulations.
- It is always recommended that this accessory is fitted by a qualified Technician.
- Safely store and protect any removed vehicle components.
- Ensure all bare metal surfaces are protected using Automotive Bare Metal Primer and touch-up paint.
- Remove all metal swarf and dust from all vehicle surfaces if surface is used for accessory installation.



### Safety Notes

- Check that all work practices comply with safety standards.
- Please wear appropriate clothing and use safety equipment.



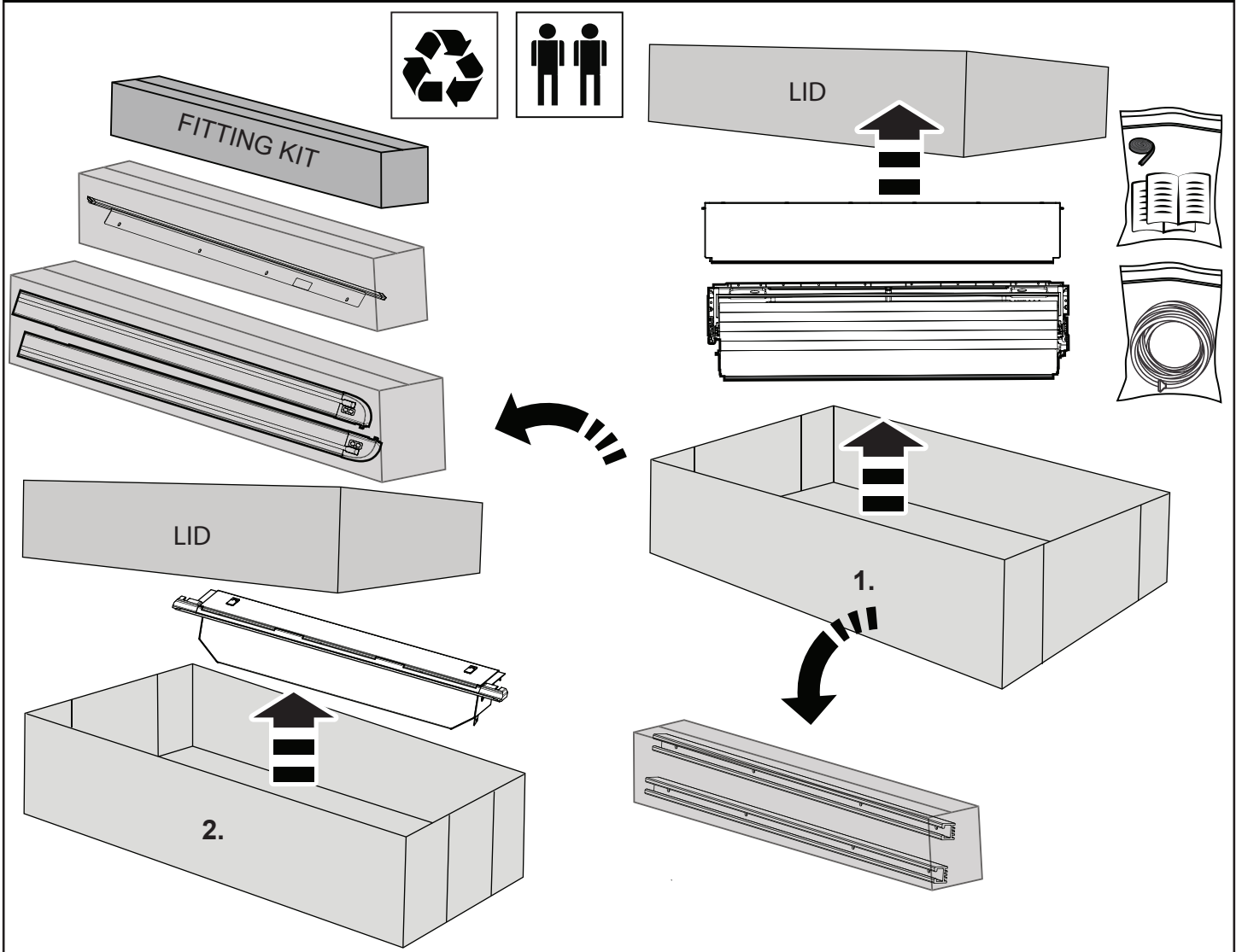
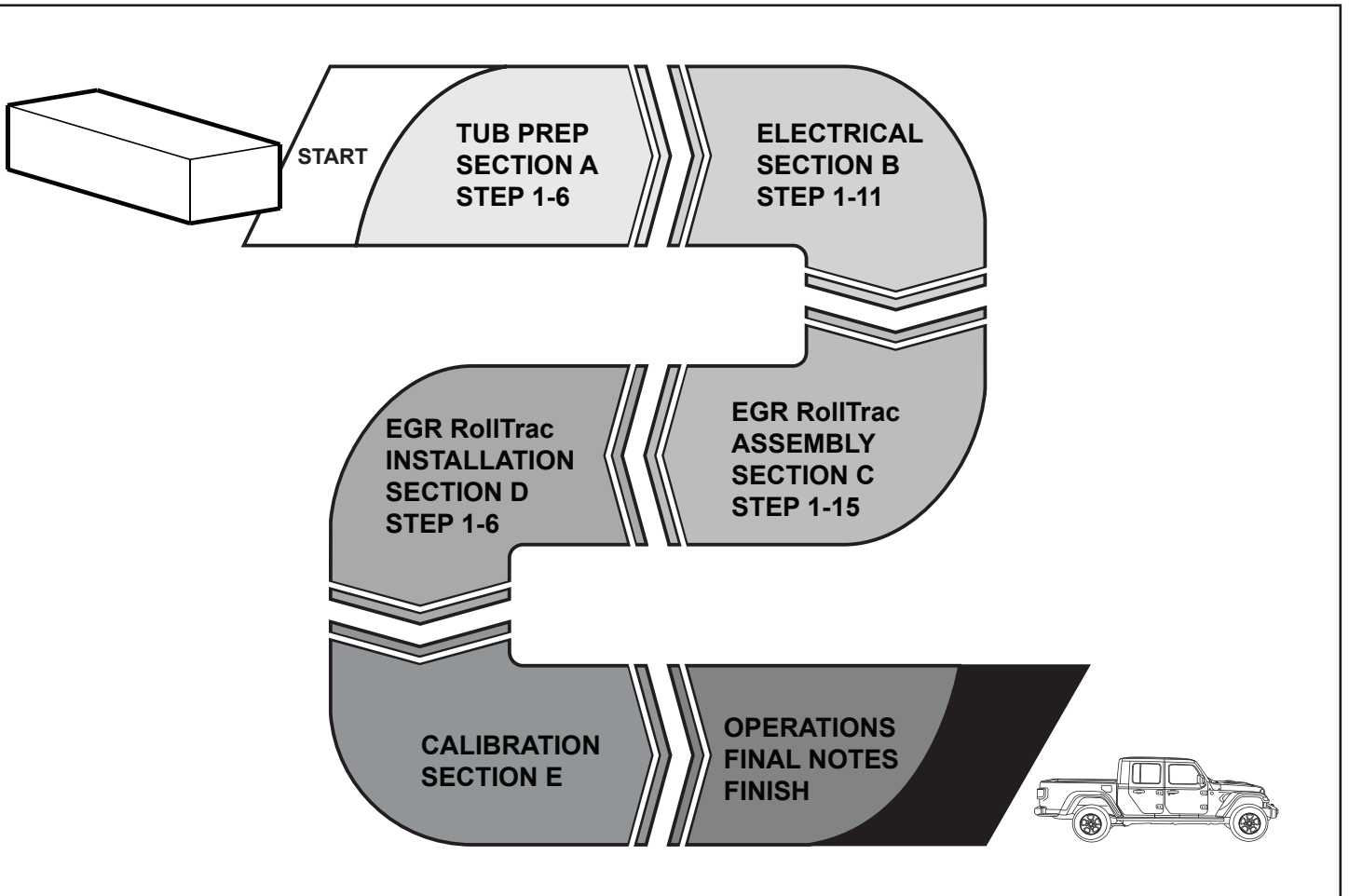

## KIT CONTENTS - COMPONENT NUMBER AND QUANTITY

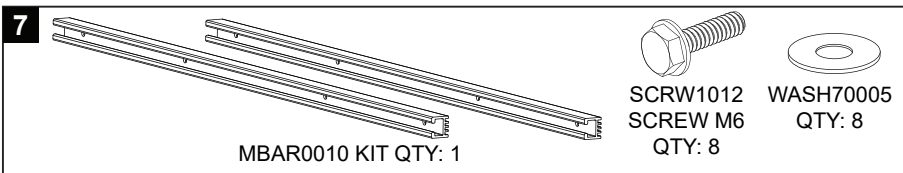
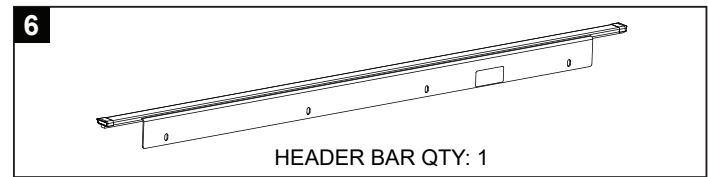
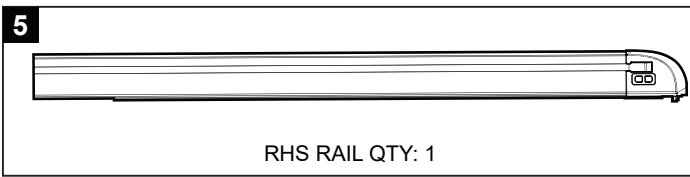
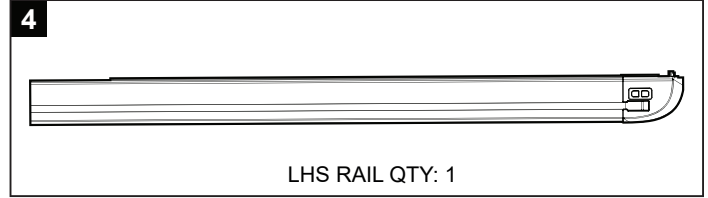
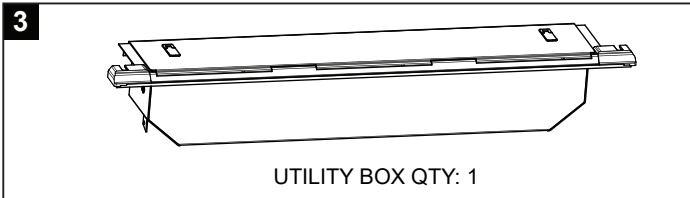
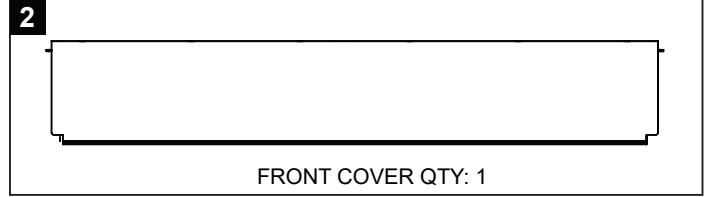

## EGR RollTrac FITTING KIT IN BOX

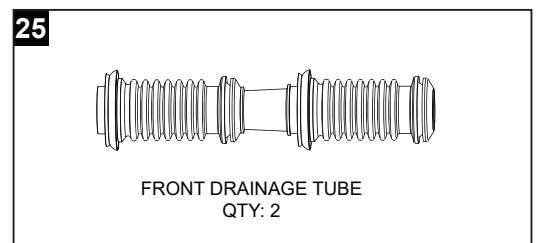
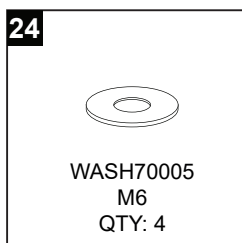
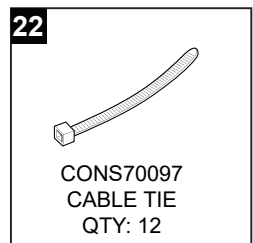
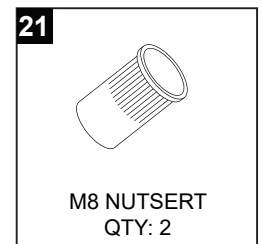
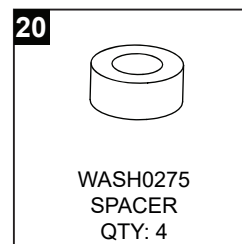
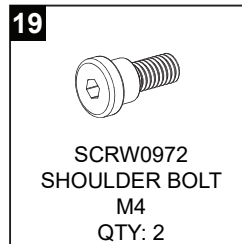
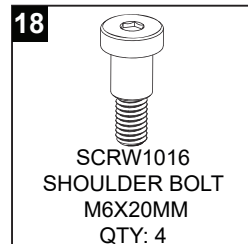
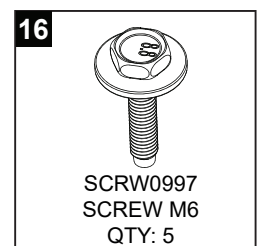
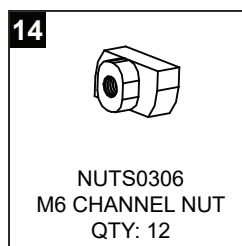
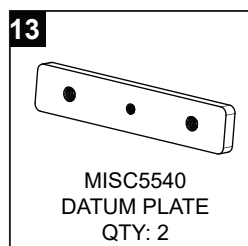
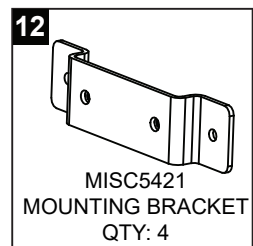
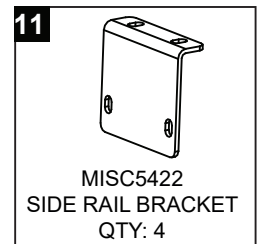
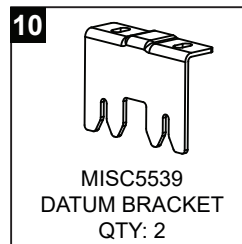
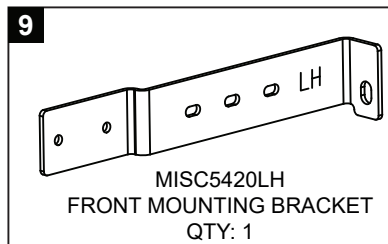
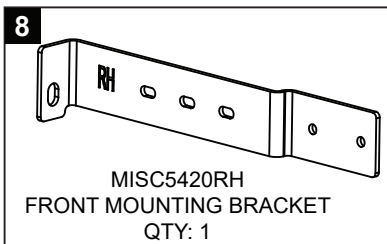

26



REAR DRAINAGE TUBE  
QTY: 2

**EGR RollTrac FITTING KIT COMPONENTS IN BAGS**

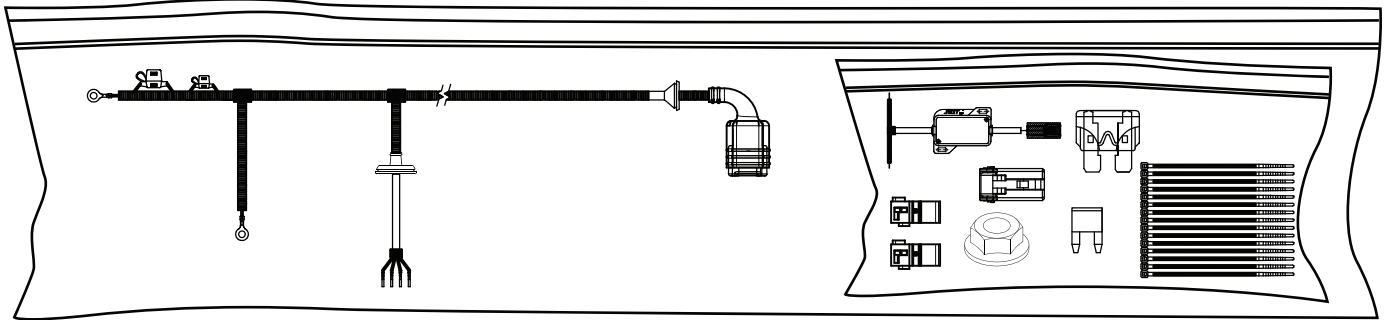

**EGR RollTrac FITTING KIT ADDITIONAL ITEMS**

INSTALLATION  
INSTRUCTIONS







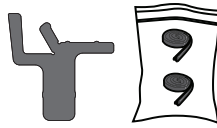

OWNERS  
MANUAL



RUBBER  
EXTRUSION  
QTY: 2

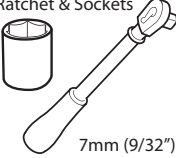
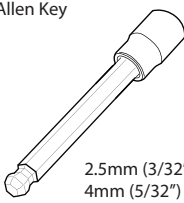

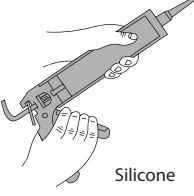
**TOOLS REQUIRED - NOT SUPPLIED IN KIT**

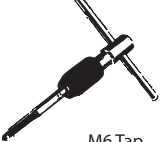
 Drill	<p>Holesaw</p>  Ø24mm (1") Ø29mm (1 1/8") Ø38mm (1 1/2")	 Centre Punch & Hammer	<p>Drill Stop</p>  Drill Bits Ø4mm (5/32") Ø11mm (7/16") Ø14mm (35/64")	 Scissors	 Masking Tape Fiberglass Tape Black Cloth Tape
<p>Ratchet &amp; Sockets</p>  7mm (9/32") 10mm (25/64") 13mm (33/64")	<p>Allen Key</p>  2.5mm (3/32") 4mm (5/32")	<p>Allen Key</p>  2.5mm (3/32") 4mm (5/32")	 Torque Wrench	 Side Cutters	 Soapy Water
 50/50 Isopropyl Alcohol/Water	 ANTI RUST Rust Inhibitor	 Silicone	 Anti-abresion tape to seal holes & slots	 Silicone Spray	 LOCTITE 243
 Nutsert Tool	 M6 Tap	<p><b>GLOSSARY:</b></p> <p><b>1</b> Number inside a square indicate part number</p> <p><b>1</b> Number inside circle indicate the sequence within a step</p> <p><b>1</b> Number inside the hexagon indicate torque instruction</p>			

# SECTION A

# TUB PREPARATION

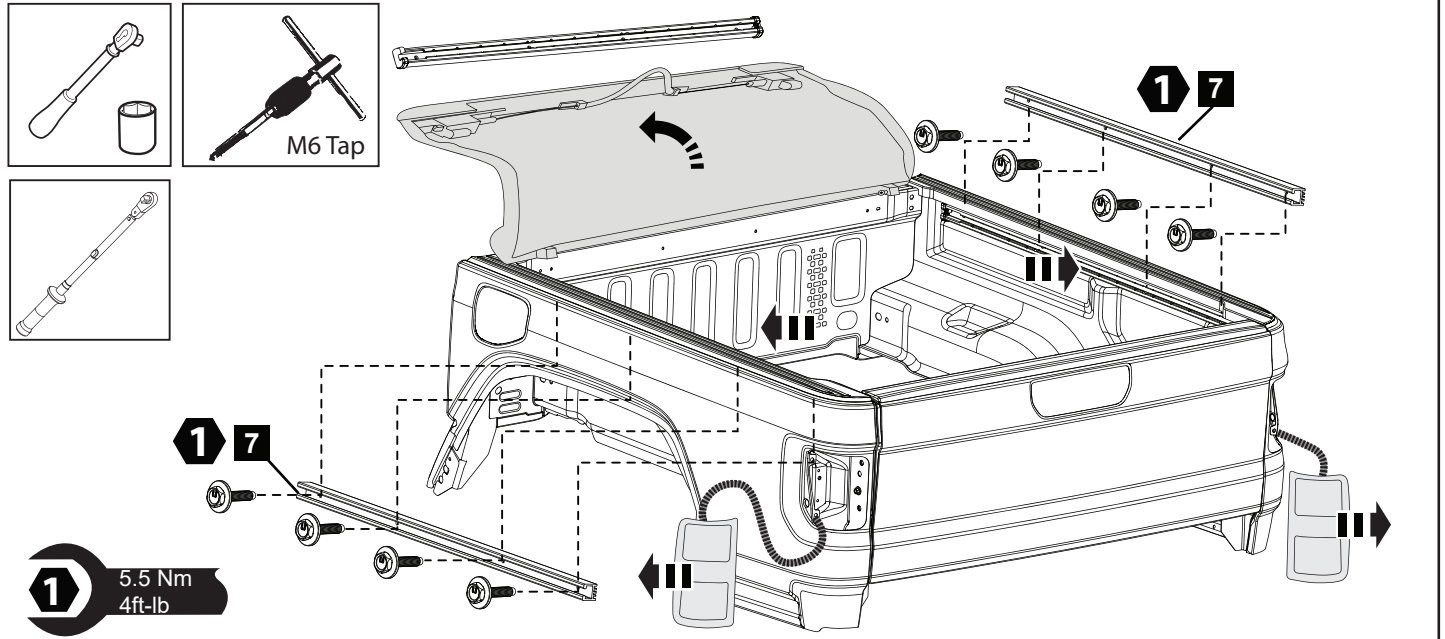

**1** Carefully remove any accessories (Soft Tonneau Cover with brackets, etc.) attached to the tub of the vehicle, if fitted. Remove the front utility rack bar. **Note:** do not remove the side utility bars. If side utility bars are not fitted, install the utility bars supplied with the EGR RollTrac (7) and torque the M6 screws to 5.5Nm(4ft-lb). Remove the tail lights and store safely. Clean the top of the tub and dry. **Note:** if the bed does not already have side rails and has a spray-in bed liner that the M6 tap must be used to clear out the thread.

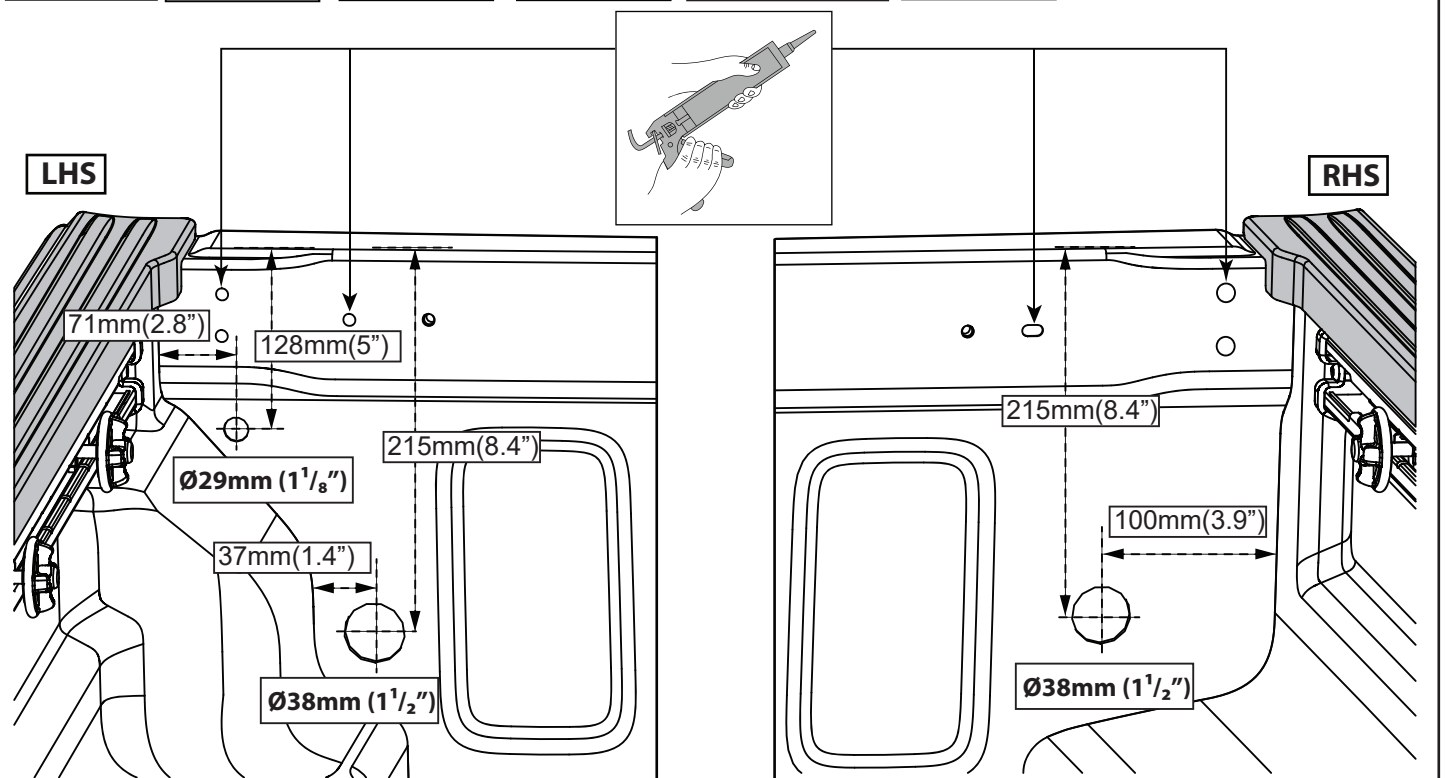
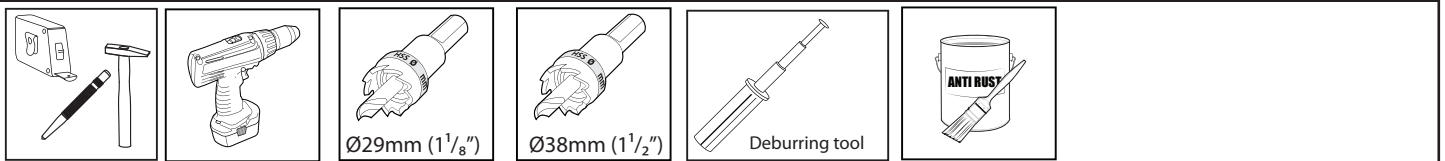

**2** Mark the position of the front drain holes and the vehicle harness in the tub front panel, centre punch the hole and drill the smaller hole only on the top left hand side with 29mm(1 1/8 inch) holesaw. Drill the drain tubes holes with 38mm(1 1/2 inch) holesaw on both sides. Clean all burrs and coat the exposed metal with a suitable rust preventative (not supplied). **Note:** Horizontal dimensions are taken from top surface of the tub. Vertical dimensions taken from the corner of the outside panels as shown. **Important:** Cover with Silicone the 4 holes in the tub, as shown.

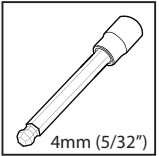
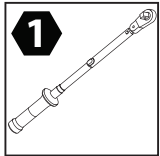

**1** 5.5 Nm  
4ft-lb

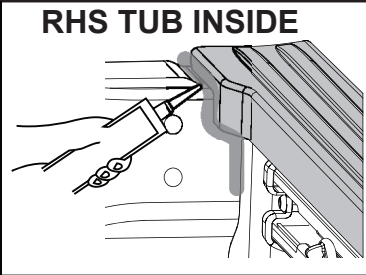
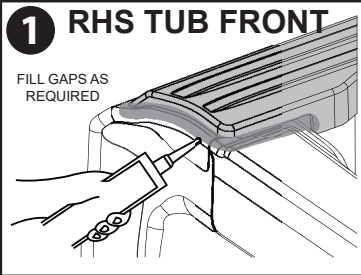

**RHS SHOWN  
REPEAT FOR LHS**

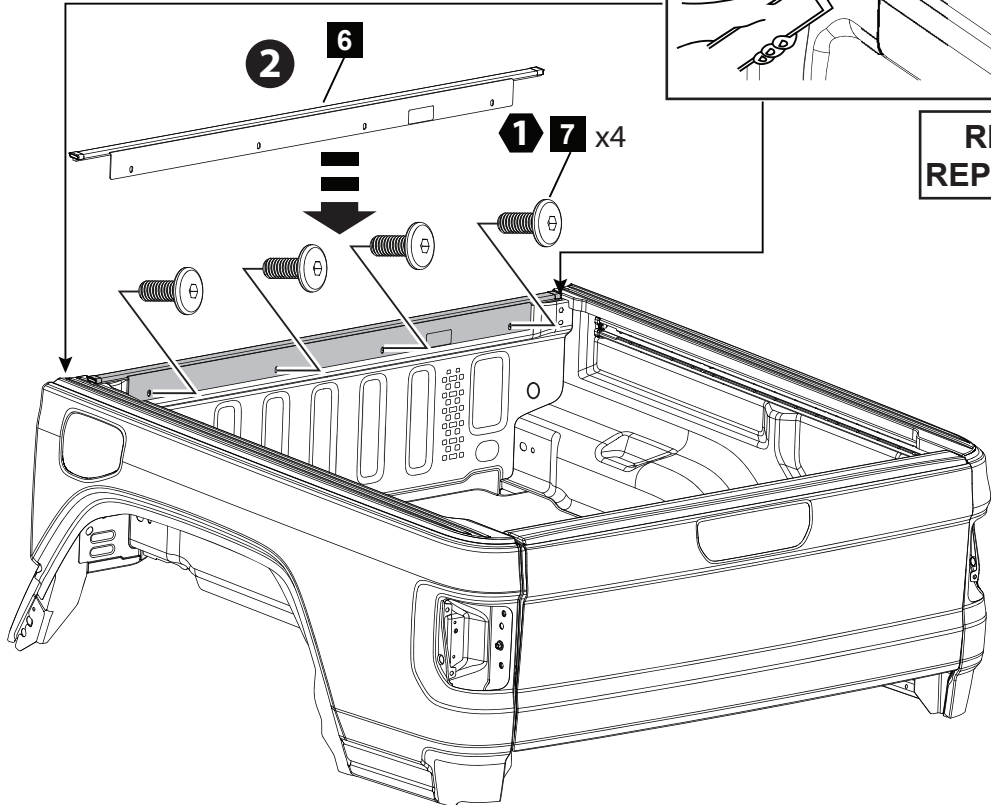

**3** Silicone the gap between the panels as shown on both sides. Place the header bar (6) on top of the tub front panel, press down and secure with four M6 screws (7). Torque to 5.5Nm(4ft-lb).

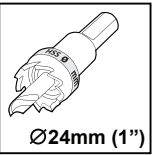
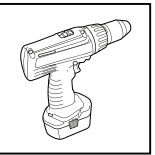
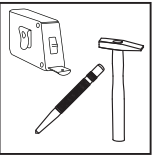

**LHS SHOWN  
REPEAT FOR RHS**

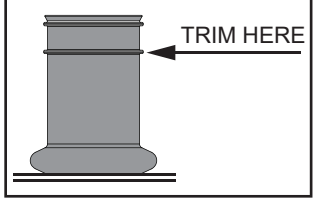
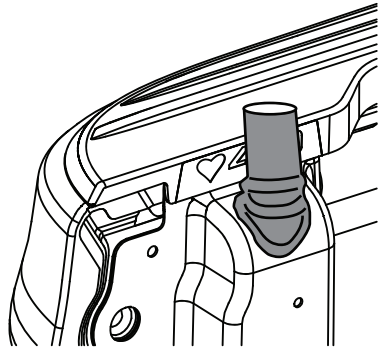
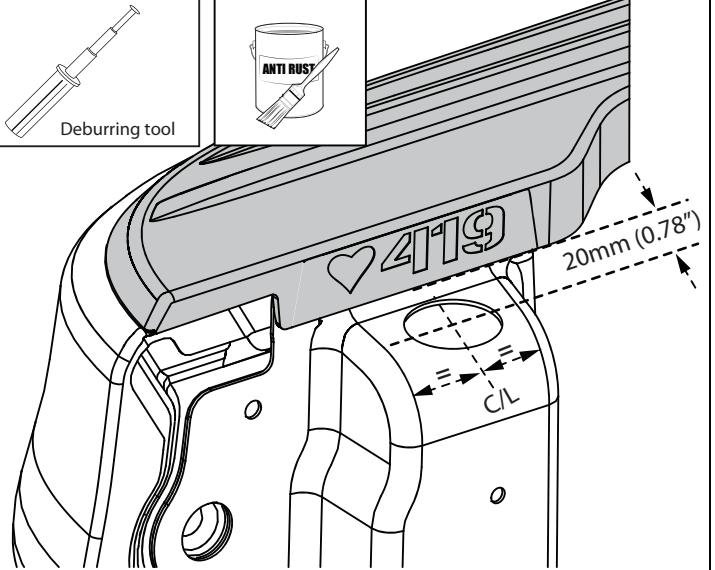
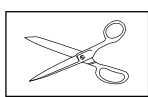
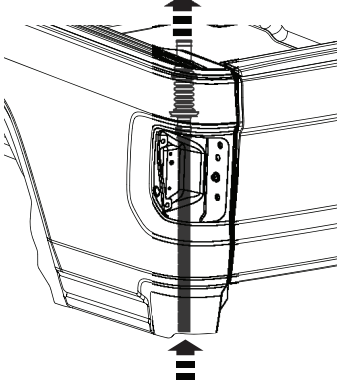

**4** Mark the position of the rear drain holes and in the tub rear panel, centre punch the hole and drill with 24mm (1") holesaw. Clean all burrs and coat the exposed metal with a suitable rust preventative (not supplied). Fit the rear drain tubes from the inside of the tail lamp cavity up through the drilled hole. Repeat this procedure for RHS.  
Note: Pull only one rib through the hole, the tube needs to be trimmed as shown.

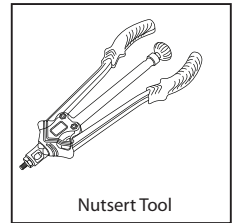
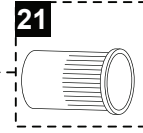
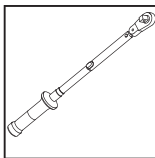
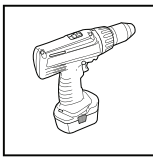

Nutsert Tool

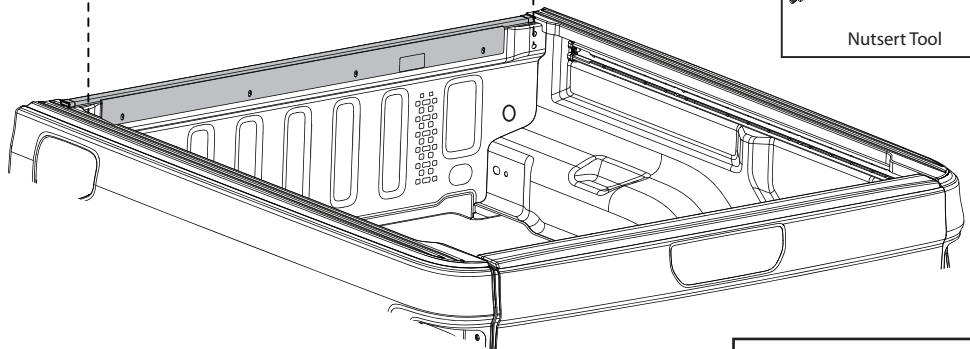

**RHS SHOWN  
REPEAT FOR LHS**

**1** 9Nm  
6.6ft-lb

**2** 5.5Nm  
4ft-lb

**3** 2.5Nm  
1.8ft-lb

**1 FRONT BRACKET PRE-ASSEMBLY**

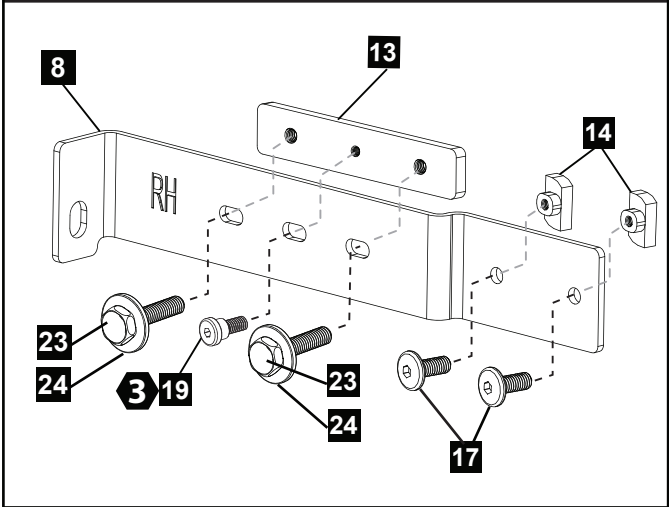

**2 FRONT BRACKET FITMENT TO TUB**

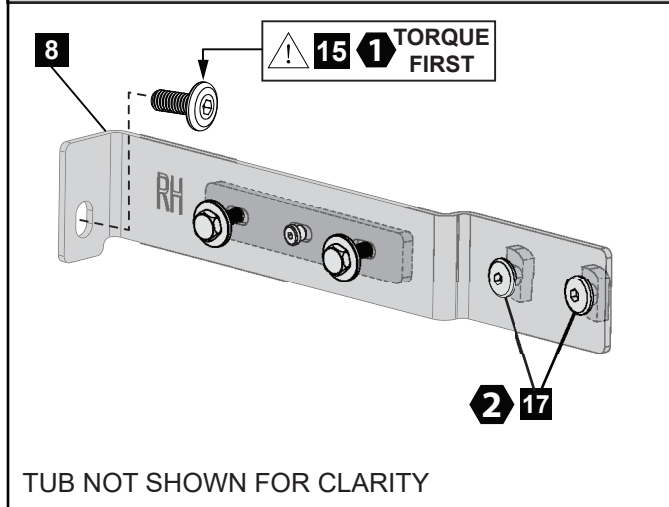

TUB NOT SHOWN FOR CLARITY

- 5** If there is no thread in the lower holes in the front tub rail, try to fit Nutserts (21) in. If not fitting, drill up to the size of Nutserts (measure the Nutsert diameter to confirm drill bit size).
1. Attach the datum plate (13) to bracket (8) using shoulder bolt (19) and two screws (23) and washers (24). Torque the shoulder bolt (19) to 2.5Nm(1.8ft-lb). Leave the screws (23) loose.
  2. Fasten the front brackets to the tub using screw (15) and torque to 9Nm(6.6ft-lb), then fit the two M6 screws (17) and torque to 5.5Nm(4ft-lb).

**RHS SHOWN  
REPEAT FOR LHS**

**SIDE BRACKET ASSEMBLY ( DO NOT TORQUE )**

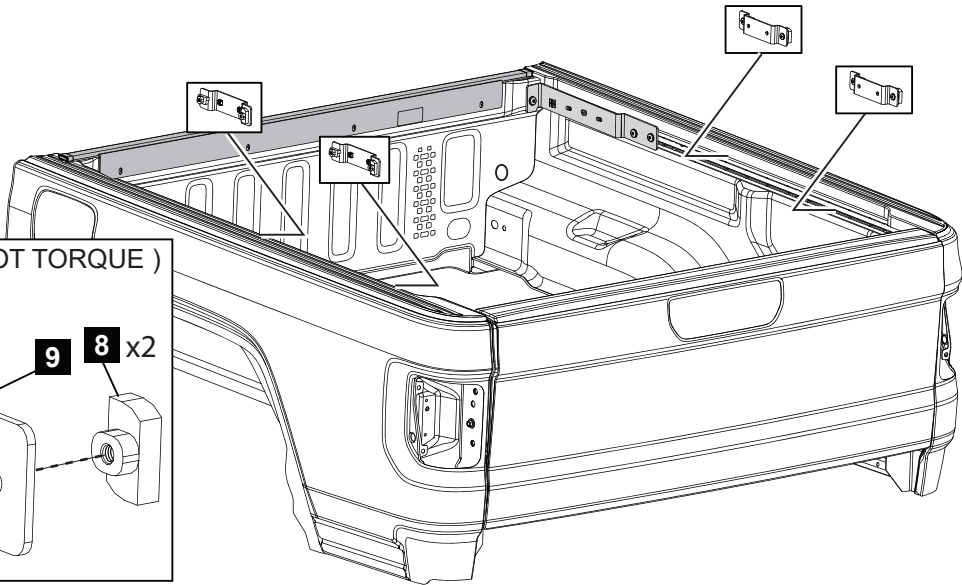
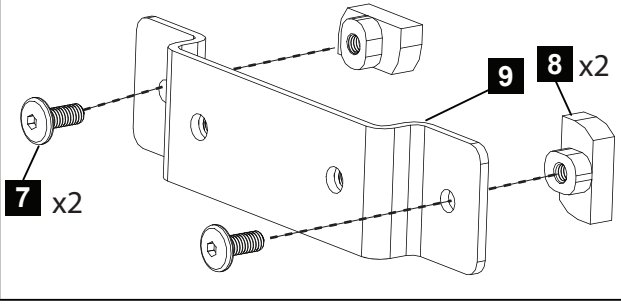

- 6** Assemble the side rail brackets (9) as shown in detail. Brackets to be mounted loose to allow side movement during installation.

**SECTION B**

**ELECTRICAL LOOM INSTALLATION**

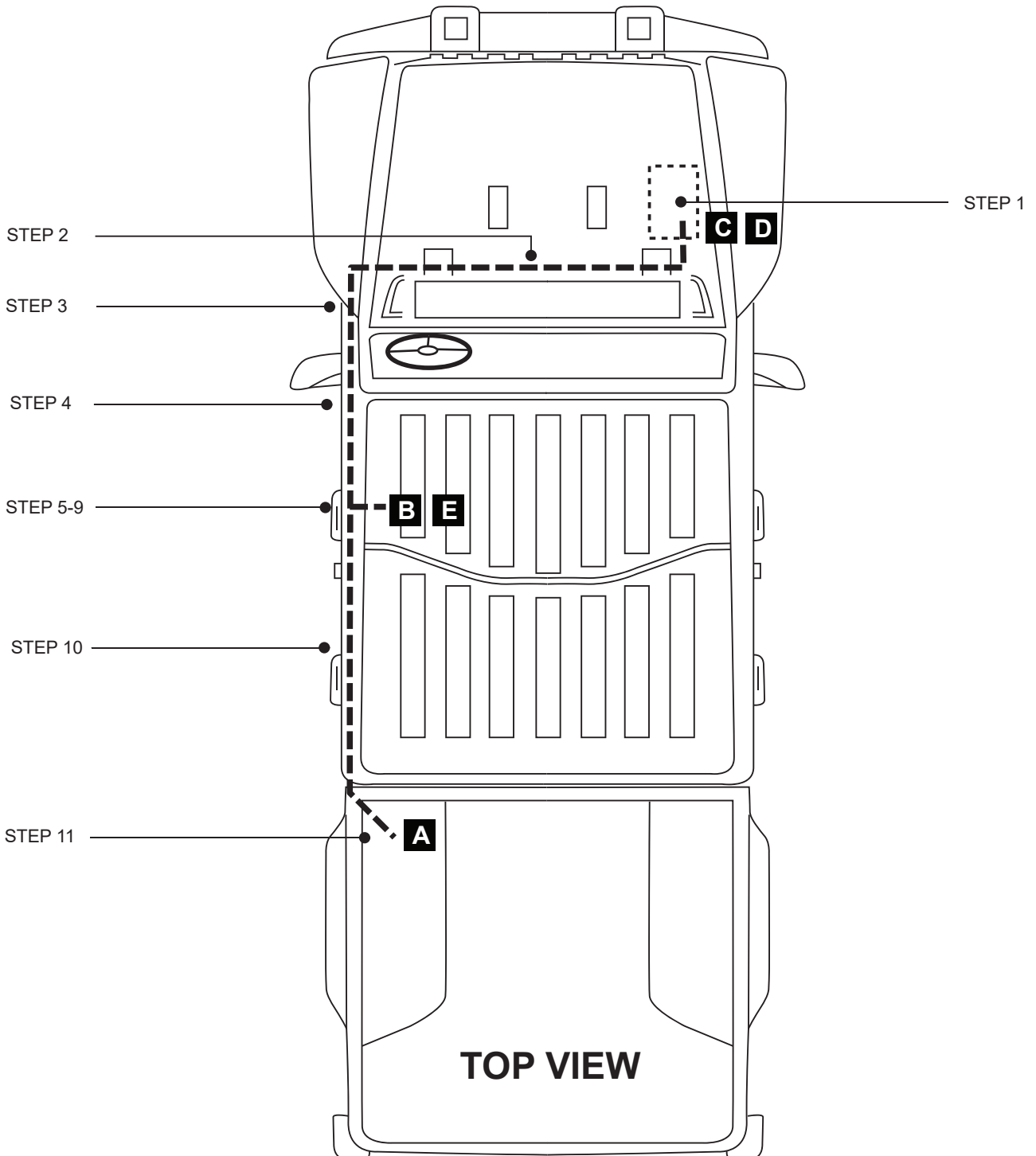
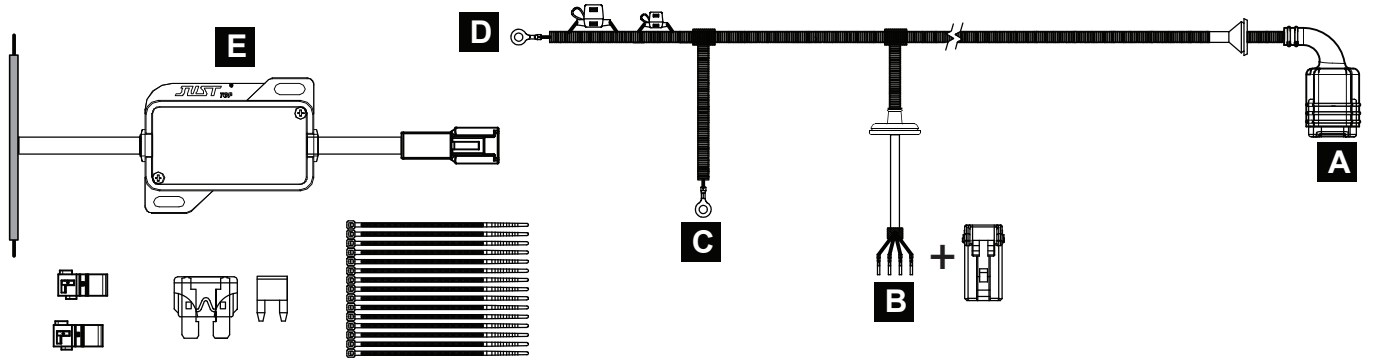





**WHILE ROUTING THE VEHICLE HARNESS AVOID ANY VEHICLE COMPONENTS THAT HEAT UP, LIKE EXHAUST AND ENGINE COMPONENTS. DO NOT ATTACH HARNESS TO FUEL LINES AND AVOID PINCH POINTS.**

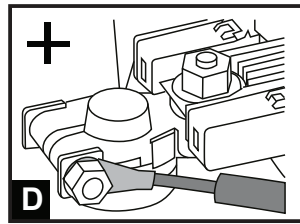
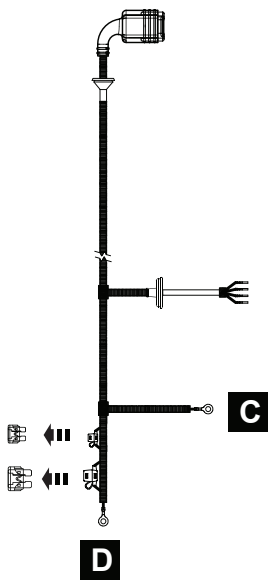

**BATTERY POSITIVE TERMINAL**

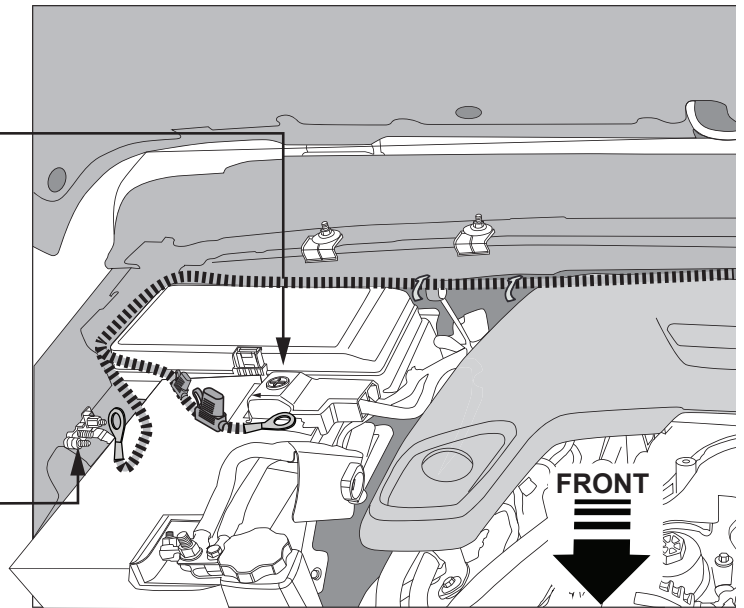
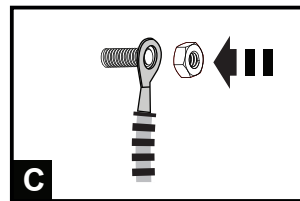

- 1 IMPORTANT:** Make sure fuses are not fitted before making connection. Connect the vehicle harness branch (C) to vehicle body negative ground, located in the engine bay as shown. Once it is positioned, secure in place using cable ties. Connect the vehicle harness branch (D) to the positive terminal of the battery. Once it is positioned, secure in place using cable ties.

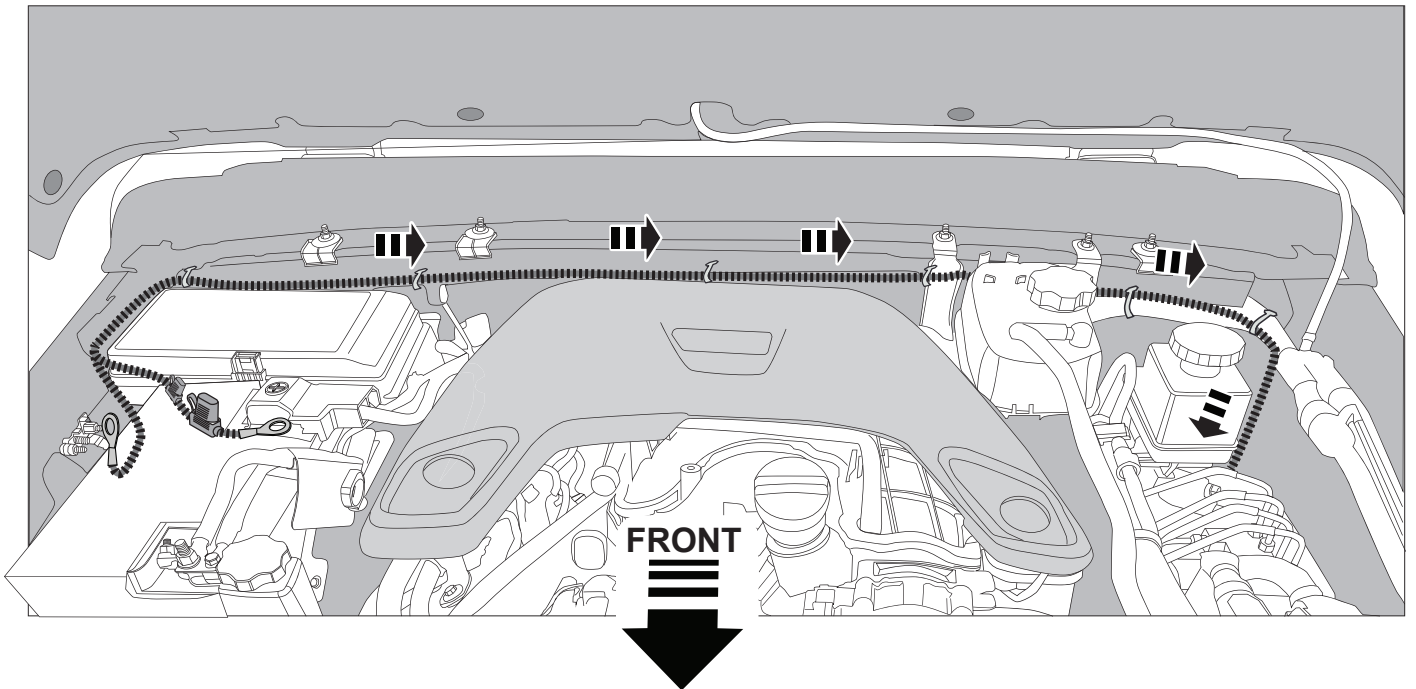
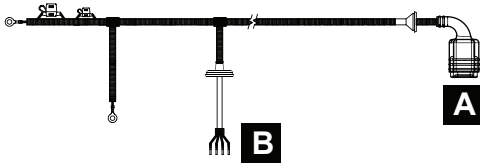

- 2** After the battery connection, run the harness (branch A&B) across the top of the firewall pass the master brake cylinder. Direct the harness down onto the factory heat shield.

**LHS**

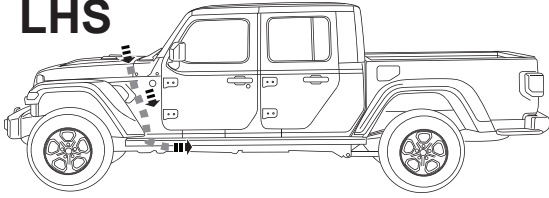

HEAT SHIELD

BRAKE LINE

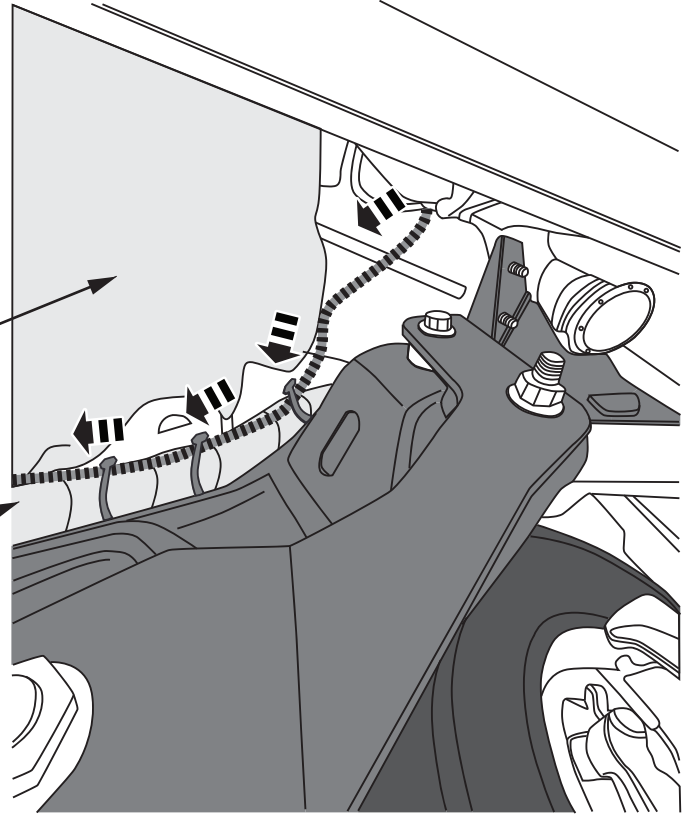
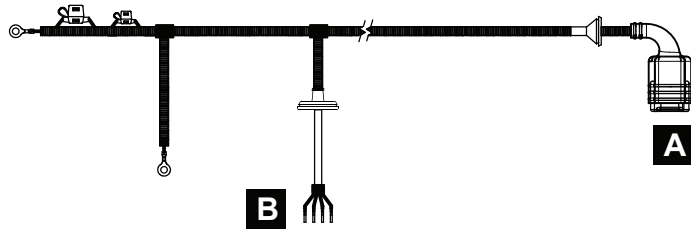

FRONT LEFT WHEEL

**3**

Run the harness from the engine bay along the factory heat shield and secure with zip ties to the brake lines every four inches.

CONTINUE ON NEXT PAGE

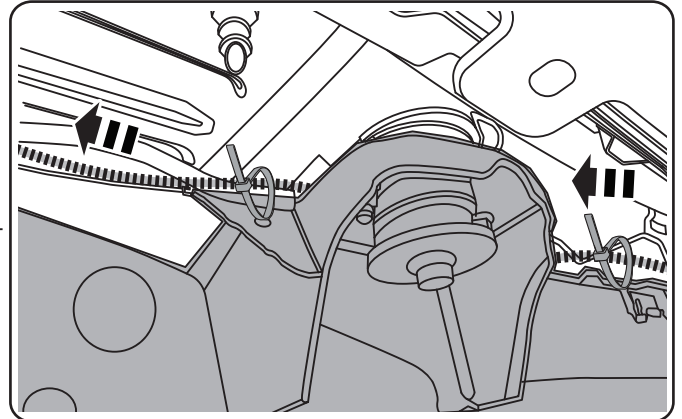
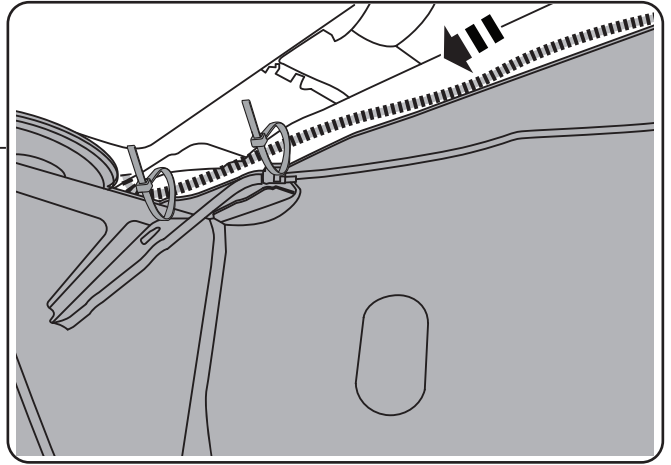
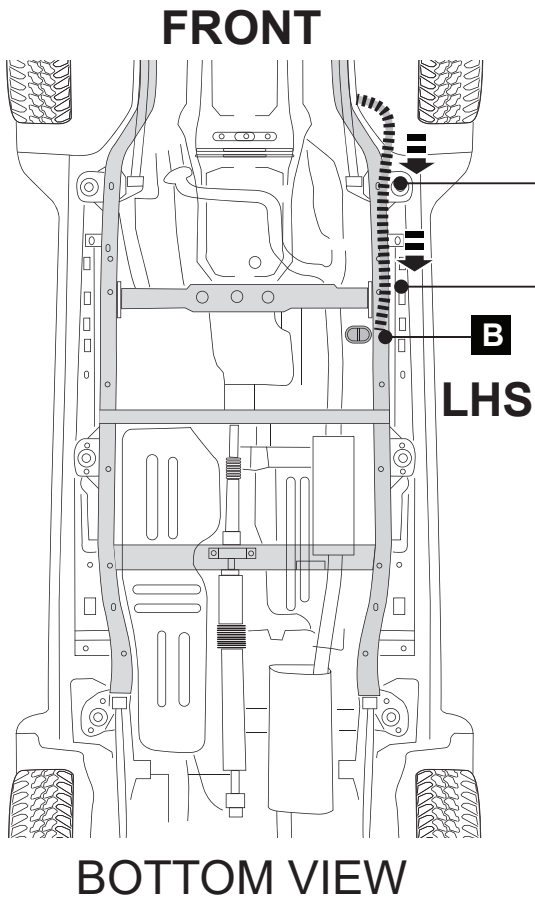

- 4** Continue running wiring loom along the chassis rail towards the rear and secure using zip ties every 12 inches until you reach the rubber grommet from under the drivers seat.

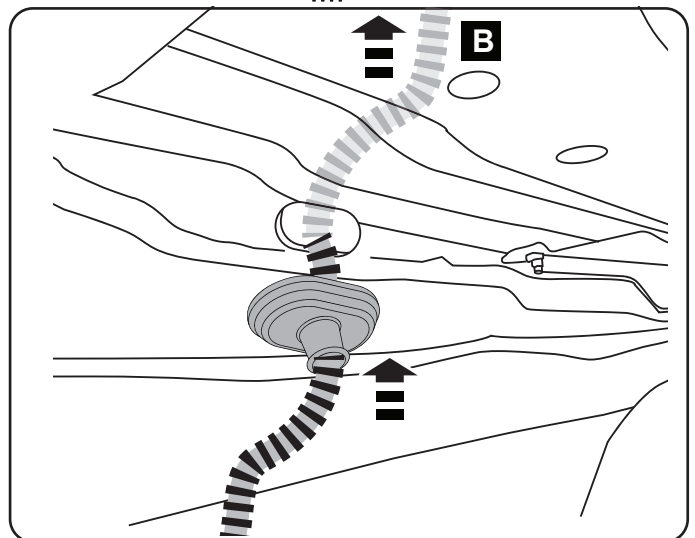
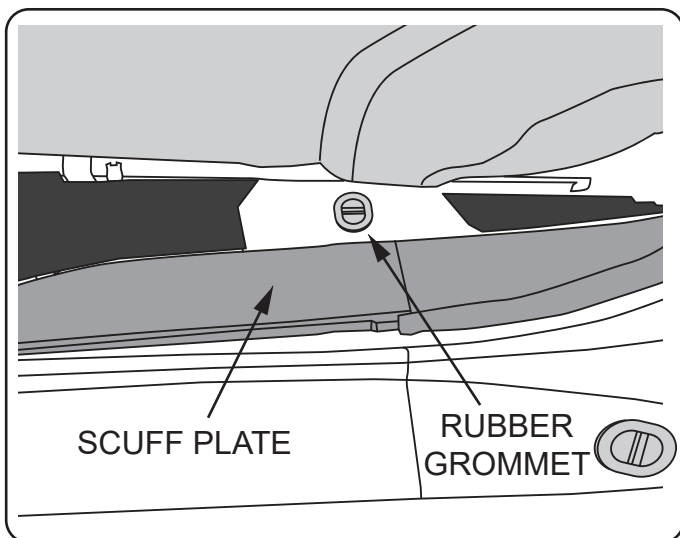
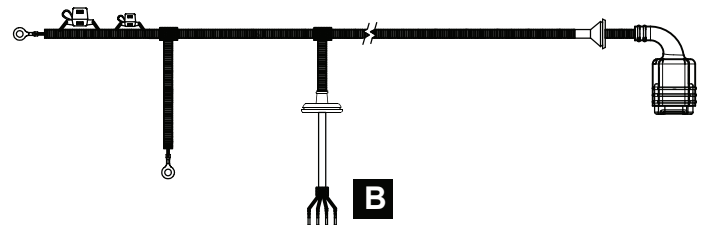
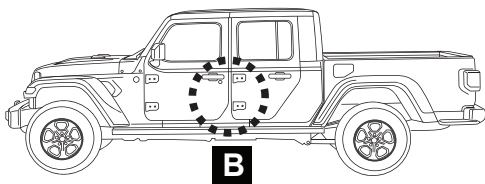

- 5** Inside the vehicle (LH) side, lift the scuff plate to allow lifting the carpet under the seat in order to expose the rubber grommet in the floor. Remove and discard the grommet. Feed the vehicle harness branch (B) into the cabin. Pull the harness until the grommet on the harness is sited securely in the floor hole.

LHS

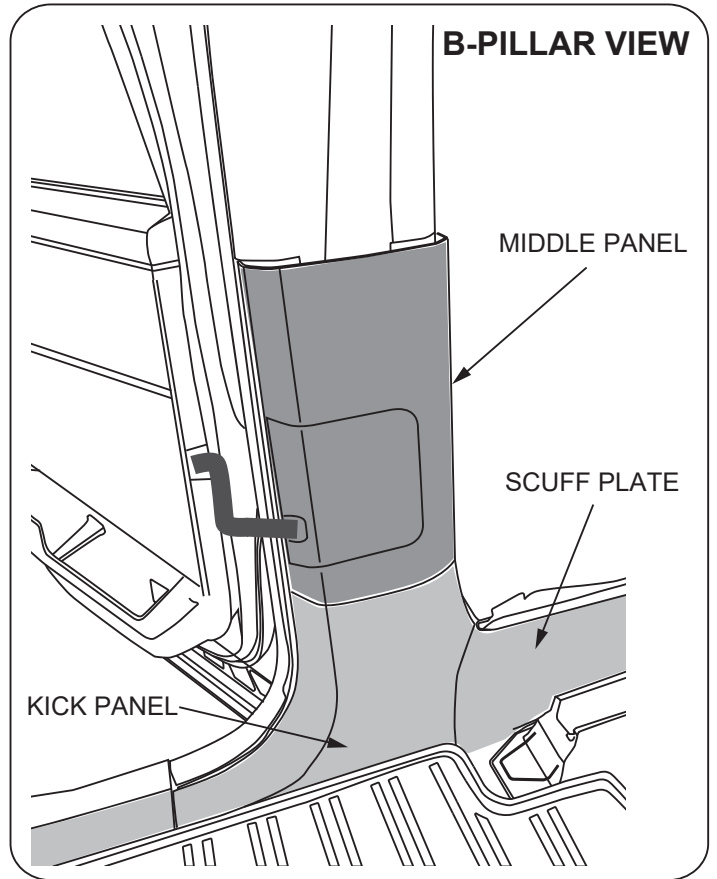
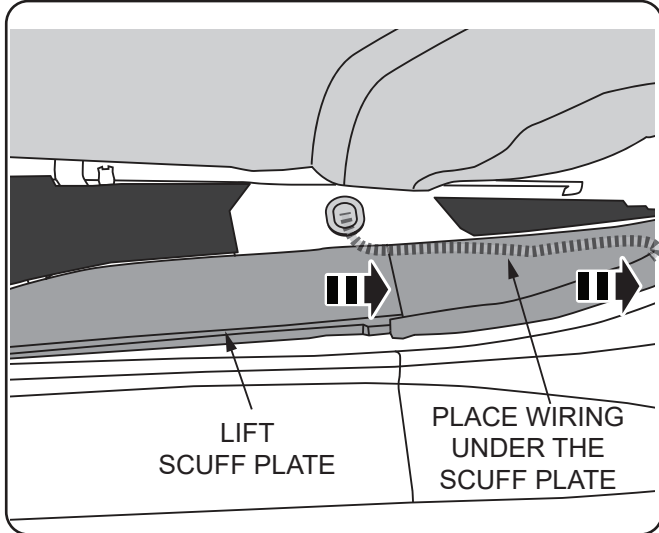
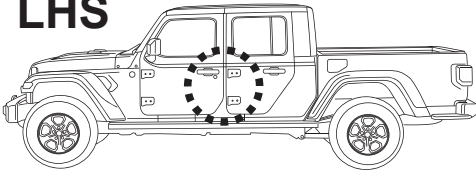

**6** Lift the scuff plate with the kick panel. Remove the middle panel on the B-pillar as shown above. Place the wiring under the scuff plate and run to the base of the B-pillar.

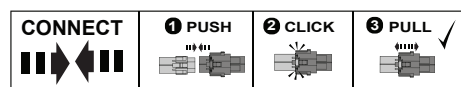
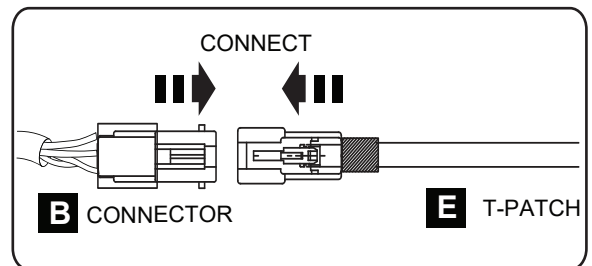
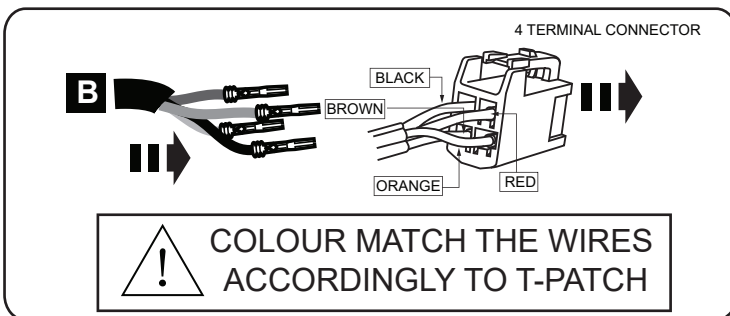
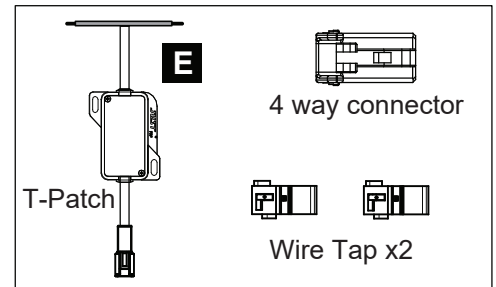
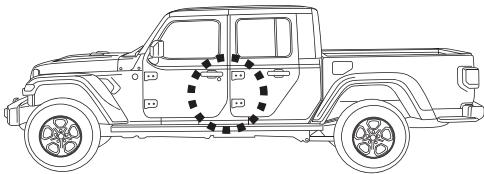

**7** Connect the 4 wires to the 4 way connector (supplied) and plug into the T-patch.  
**Note: Make sure the wires are colour matched to the wires in the T-patch connector.**

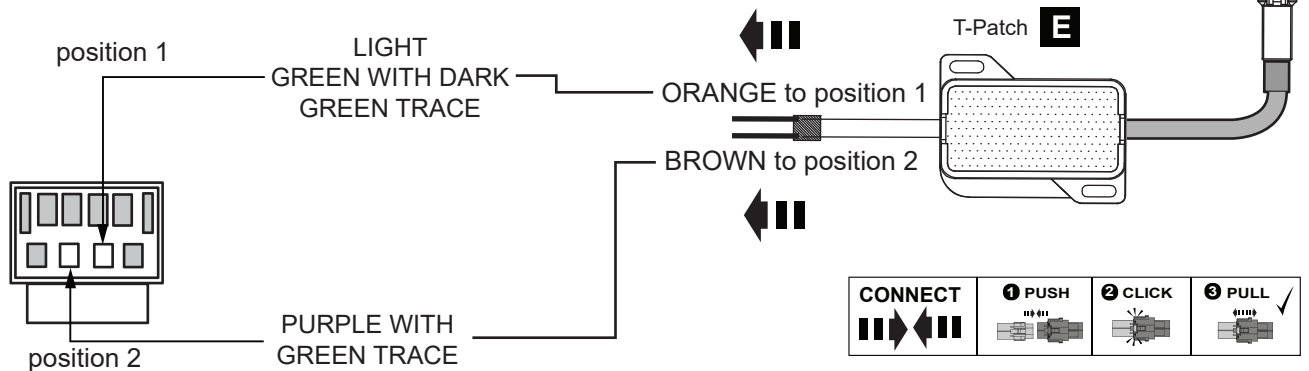
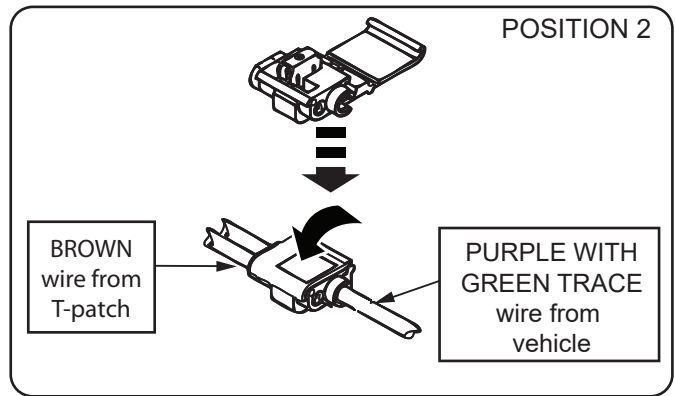
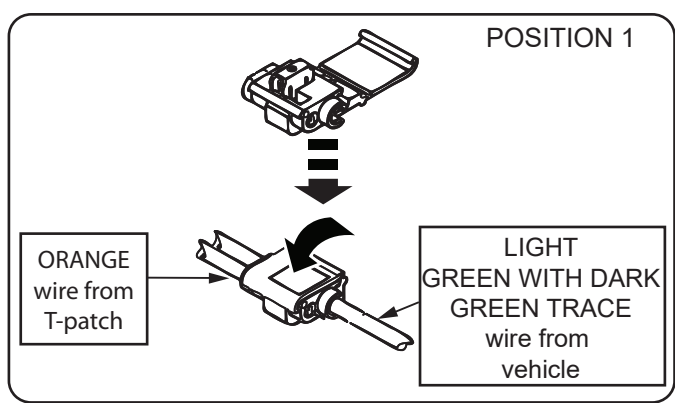
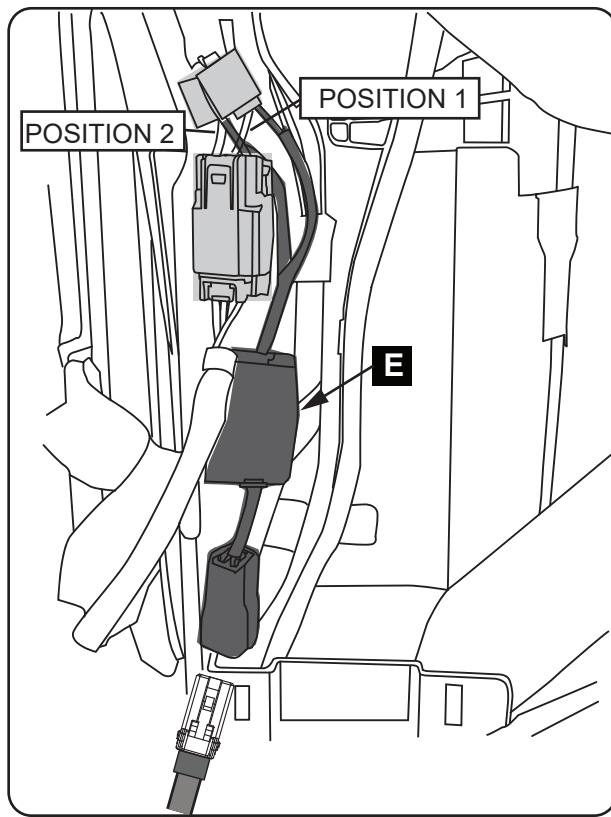

- 8** Connect the vehicle harness (C) to the T-patch (E). Splice the designated wire as shown from the vehicle harness with corresponding wire from RollTrac T-patch harness using the supplied wire tap.  
 Note: Clamp down firmly on metal component in the wire tap.

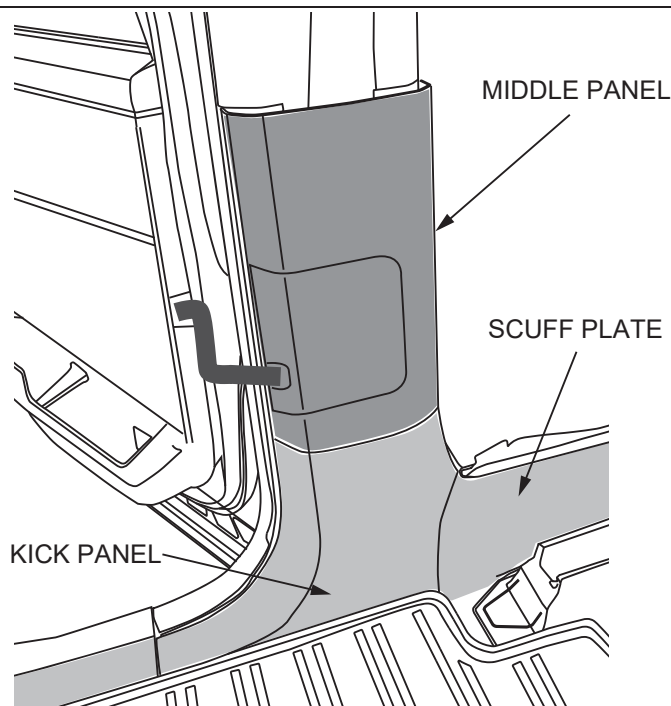

- 9** Refit the scuff plate with the kick panel and the middle panel on the B-pillar as shown above.

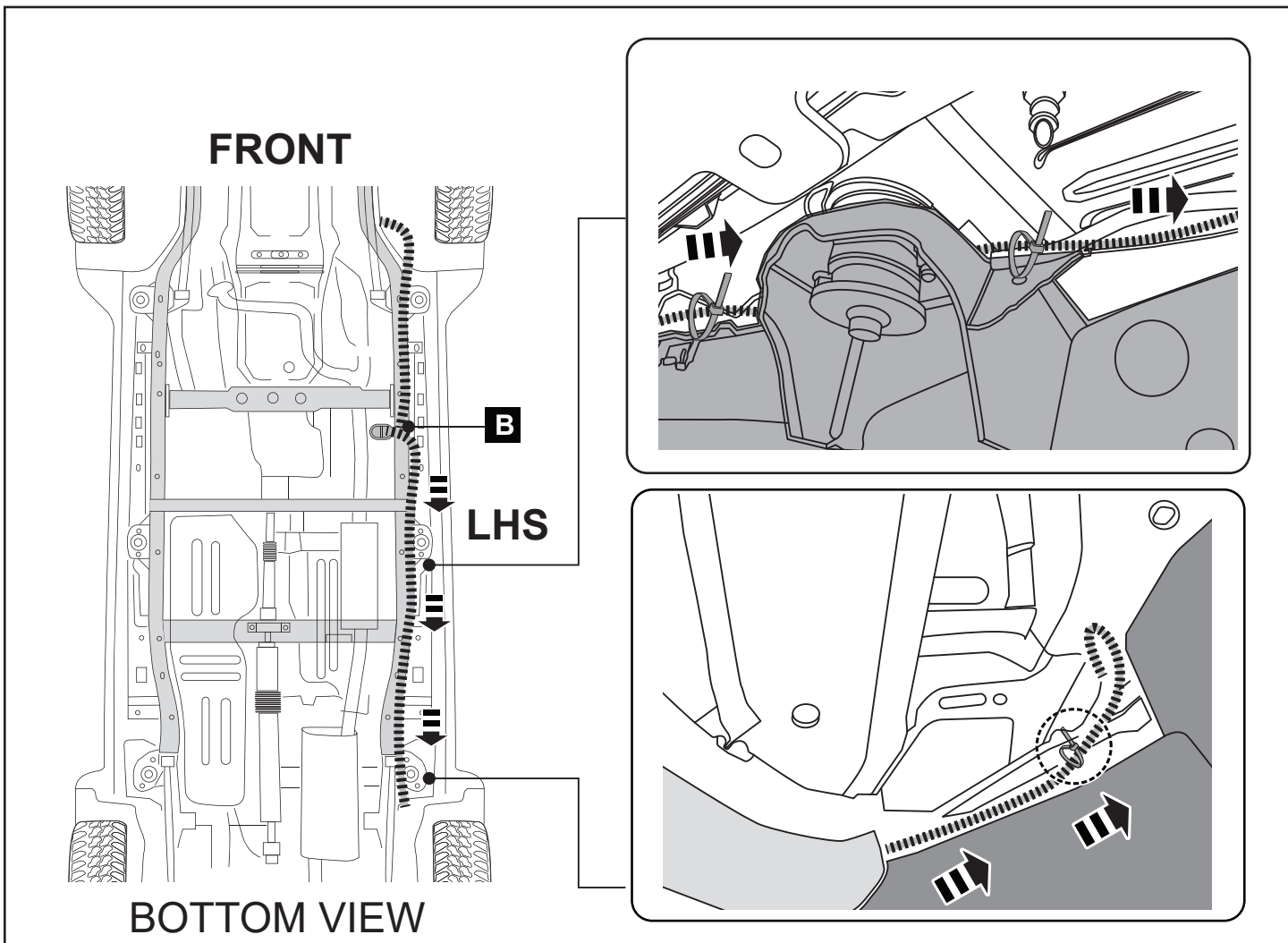

- 10** Continue running wiring loom along the chassis rail towards the rear and secure using zip ties every 12 inches until you reach the tub.

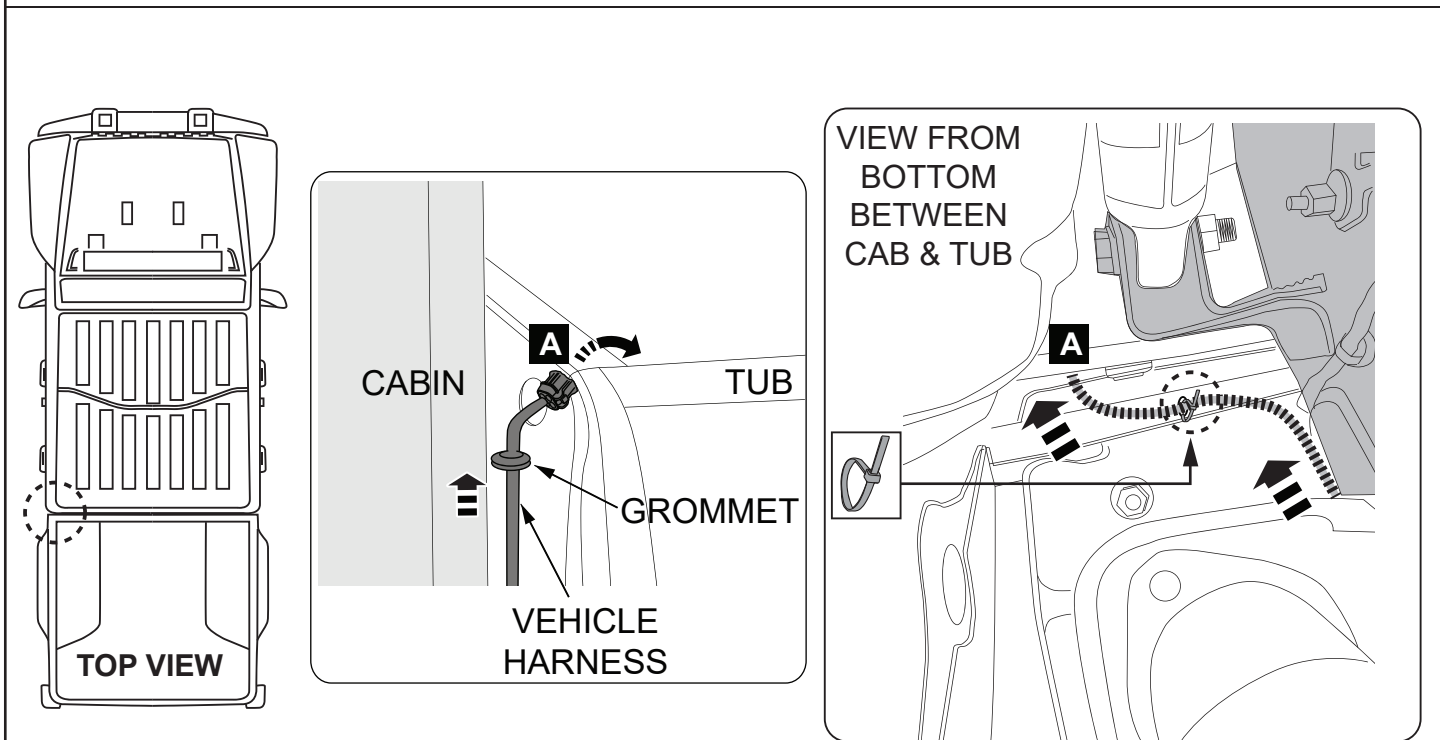

- 11** Start in between cab and tub from outside, feeding ECU back into tub, with the connector (A) at the top of the tub towards the gap between cabin. Pull the harness into the tub through the previously drilled hole until it seals with the grommet in the drilled hole. At the bottom of the tub locate hole in the cabin sheet metal and zip tie the harness to the cab.



DURING ASSEMBLY PROCEDURE SUPPORT AT CENTRE OF CANISTER ONLY, PLACE ON TOP AND BASE CARTON (OR SIMILAR), COVER WITH FOAM BLANKET. TO AVOID SCRATCHING POWDERCOATED SURFACES.

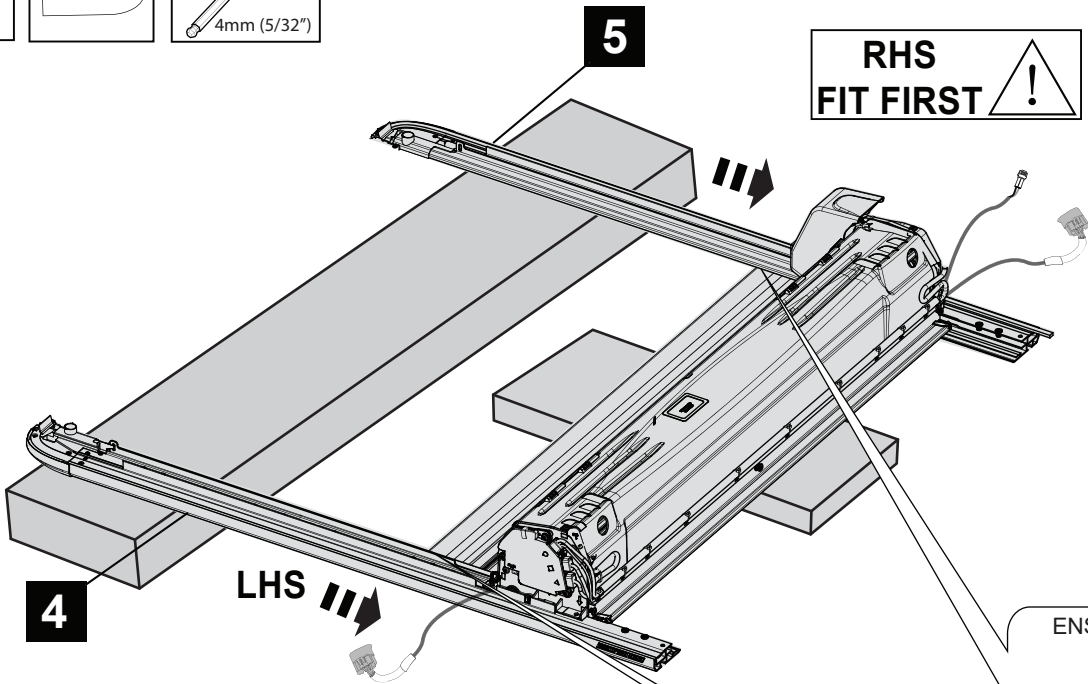
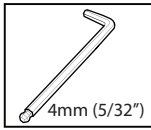
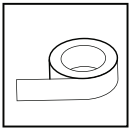

1



ATTENTION: SEAL MUST FACE IN THE DIRECTION AS SHOWN. WARRANTY VOID IF ASSEMBLED INCORRECTLY.

HOLD SEAL FLAT  
USE CLOTH TAPE

RHS SHOWN

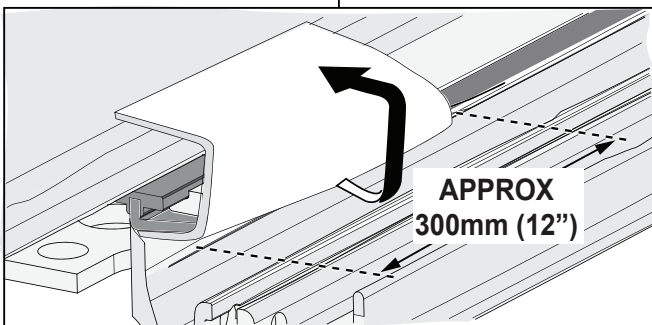
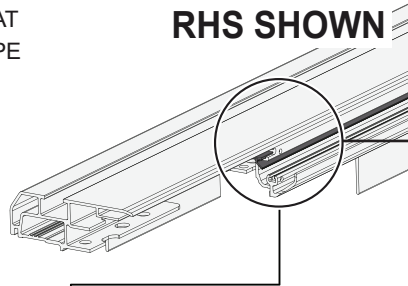
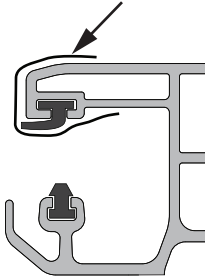

ATTENTION: WIPE THE SEAL AND SIDE RAIL WITH WAX & GREASE REMOVAL TO ENSURE THE CLOTH TAPE WILL ADHERE TO THE SIDE RAIL AND SEAL

- Place the canister (1) on two protected boxes as shown, ensure hand rail and slat ends are aligned. Tape up the seal on the Side Rail (5) as shown.  
**IMPORTANT:** Carefully align and slide the rail over the handrail and canister endplate taking particular care to ensure that the siderails are slid straight and no undue force is applied to the rail. Details in following steps.

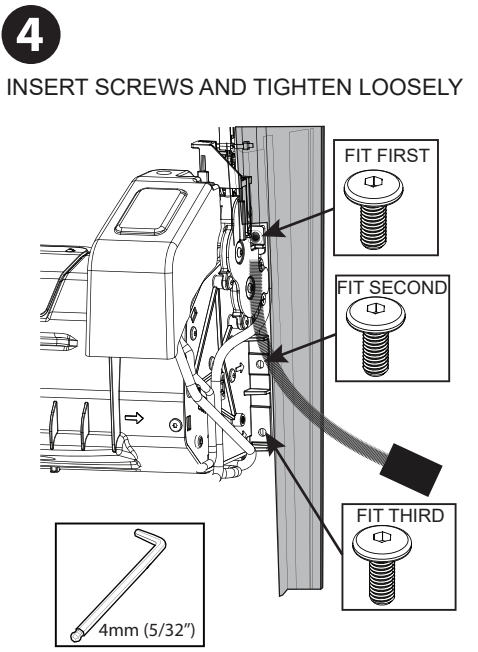
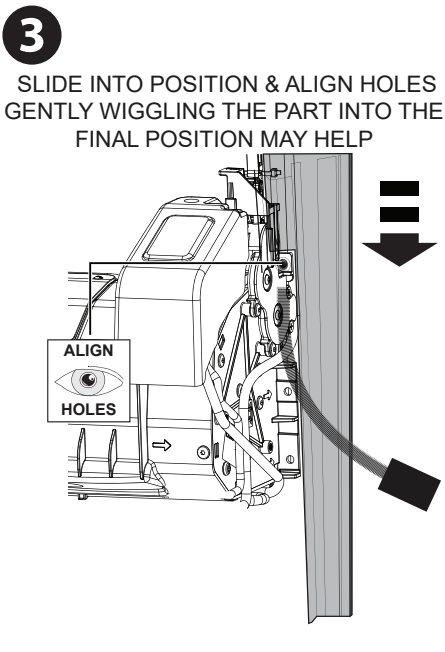
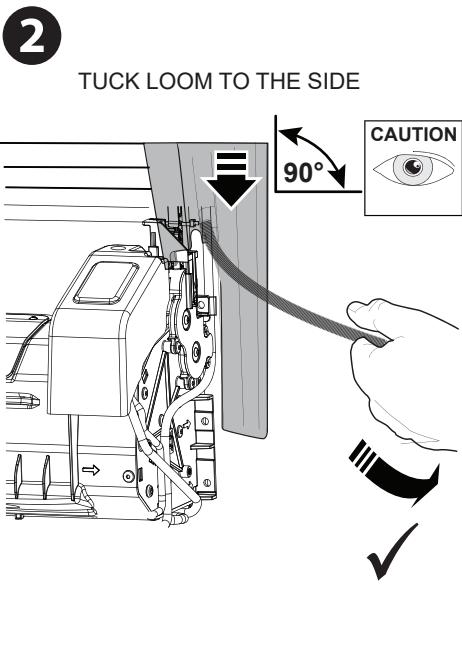

**2** Pull hand rail to expose 3 slats. Slide the RHS Rail over slat ends and onto endcap location pins. Align the holes and secure loosely with 3 screws (7). Do not tighten. Repeat for LHS Rail (4).

! DURING ASSEMBLY PROCEDURE SUPPORT AT CENTRE OF CANISTER ONLY, PLACE ON TOP AND BASE CARTON (OR SIMILAR), COVER WITH FOAM BLANKET. TO AVOID SCRATCHING POWDERCOATED SURFACES. !

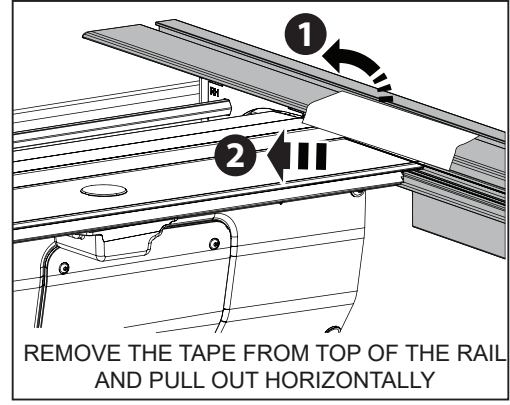
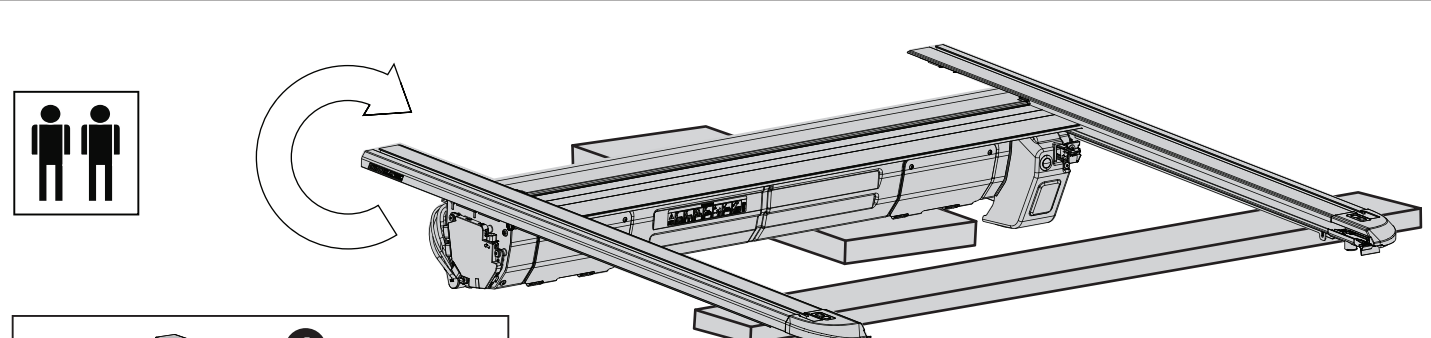

**CAUTION**  
ALIGN CAREFULLY

! ATTENTION: SEAL MUST FACE IN THE DIRECTION AS SHOWN. WARRANTY VOID IF ASSEMBLED INCORRECTLY.

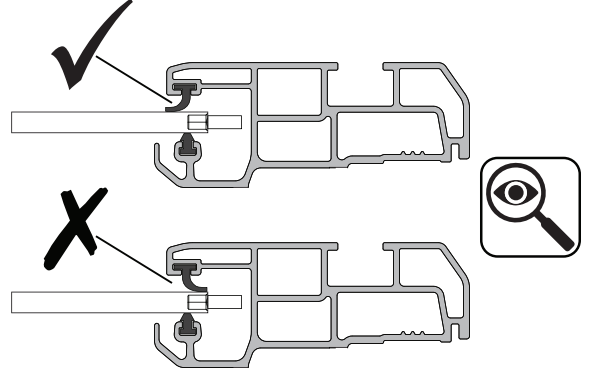
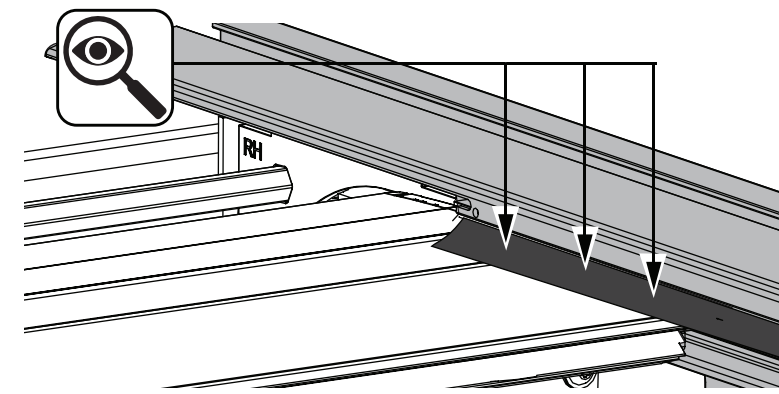

CHECK SEAL IS IN POSITION AND NOT DAMAGED

**3** Carefully lay the assembly over onto a protected surface. Remove the tape holding the rubber seal and check the seal position as shown. Repeat for LHS Rail (4)



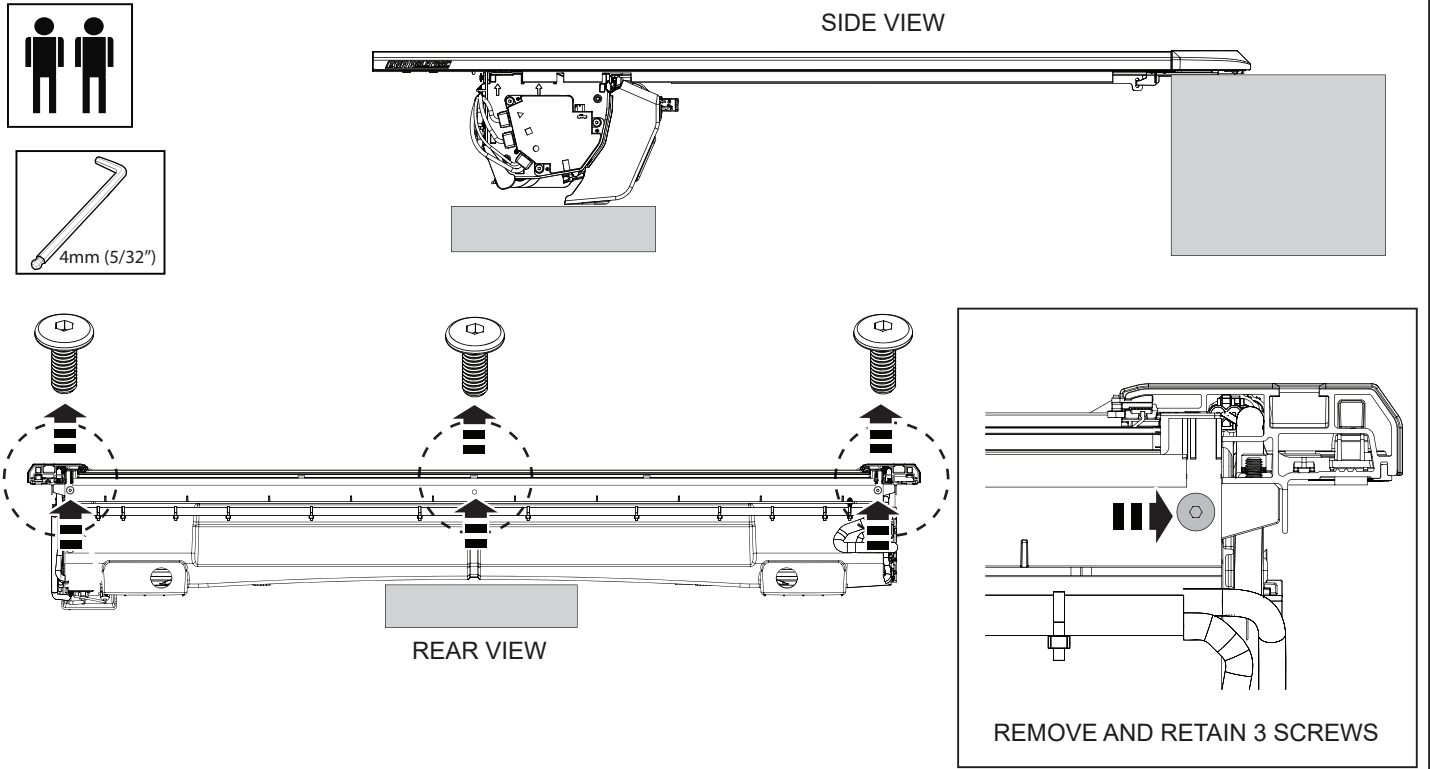

**4** Remove and retain for later refitment the 3 pre-fitted screws from the front of the canister assembly which will be used to secure the front cover (1) to the canister assembly. Ensure the product is not scratched or damaged when laying flat. **IMPORTANT:** Do not apply load to the electrical connectors and do not sit product on motor cover.

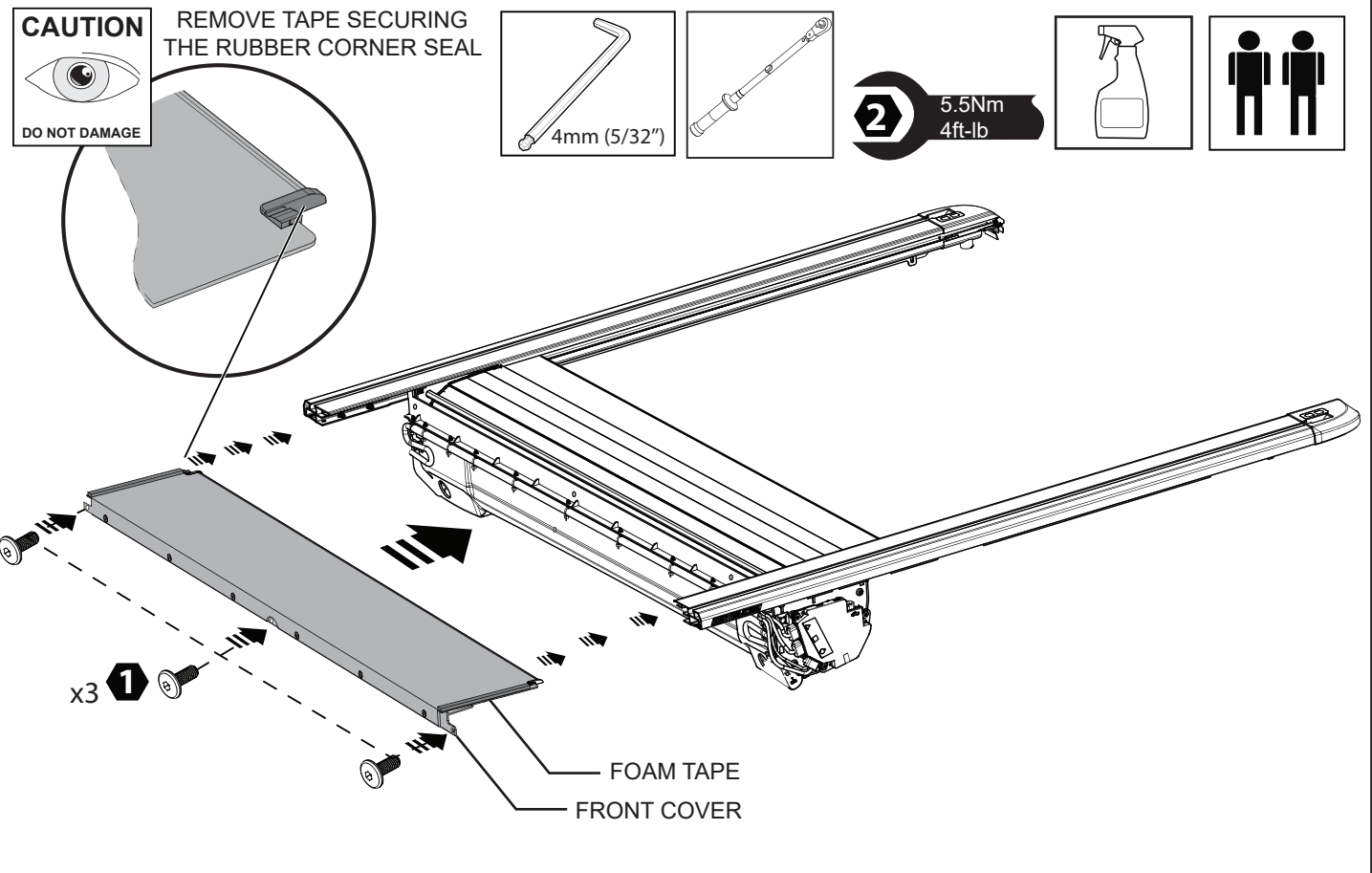

**5** Slide the Front Cover (2) over the canister and into the side rail channels. Ensure that the foam tape and the small rubber corner seal on the RHS and LHS of the front cover are not damaged. **IMPORTANT:** Twisting side rails outwards will also help. Secure the front cover to the canister assembly with 3 screws, removed in step 4. Torque to 5.5Nm(4ft-lb).

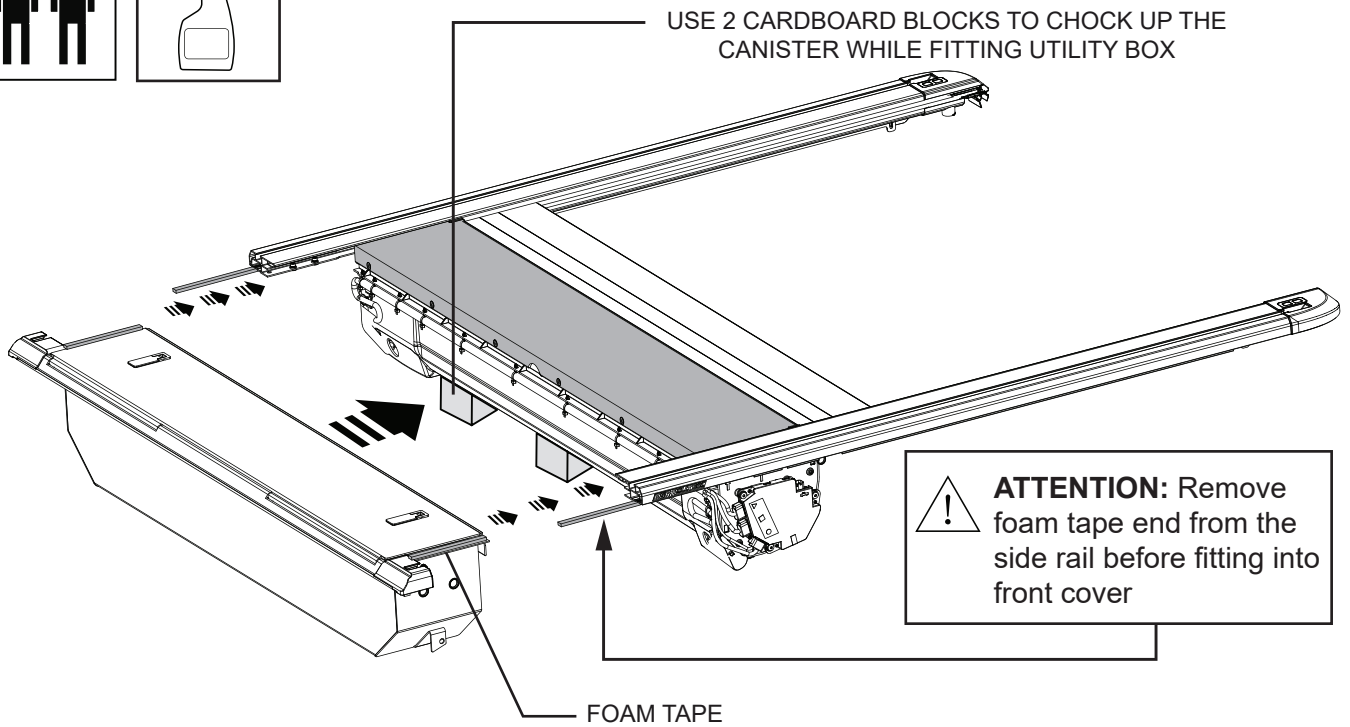

- 6** Slide the Utility Box (3) into the side rail channels ensuring that the foam tape on the RHS and LHS of the utility box are not damaged. Also ensure that the foam tape on the RHS and LHS hanging from side rails is removed and not damaged.  
IMPORTANT: Spray the front cover edge with soapy water to allow it to slide easily into the sides, twisting side rails outwards will also help.

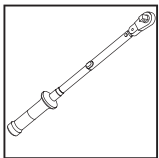

**1** 5.5Nm  
4ft-lb

**1** 16 x5

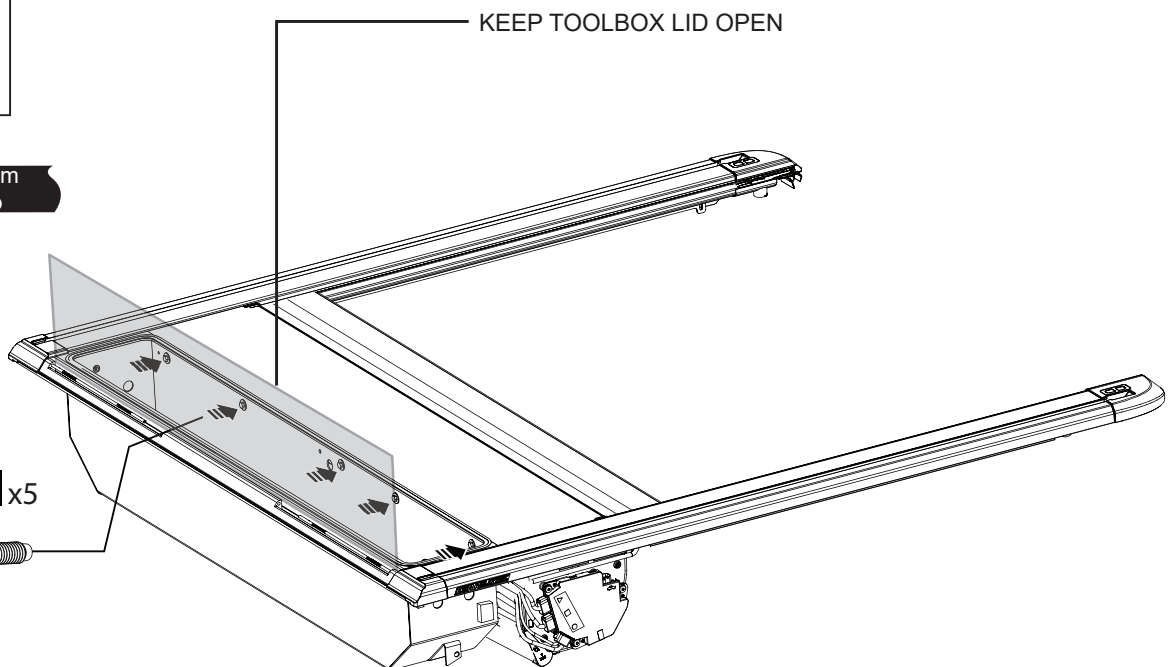

- 7** Secure the Utility Box (3) to the canister with 5 screws (16). Once in place, torque to 5.5Nm (4ft-lb).

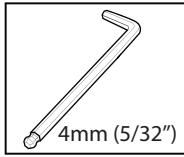
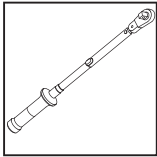

**1** 5.5Nm  
4ft-lb

ROLLOVER THE ROLLTRAC  
AND PLACE ON CARDBOARD BOXES

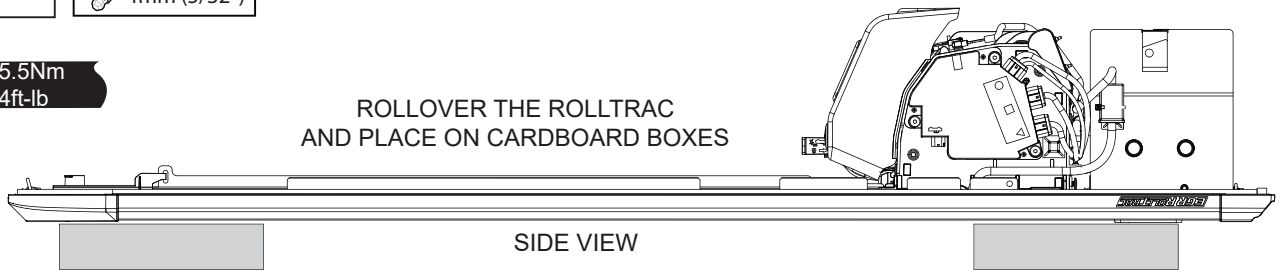

LHS

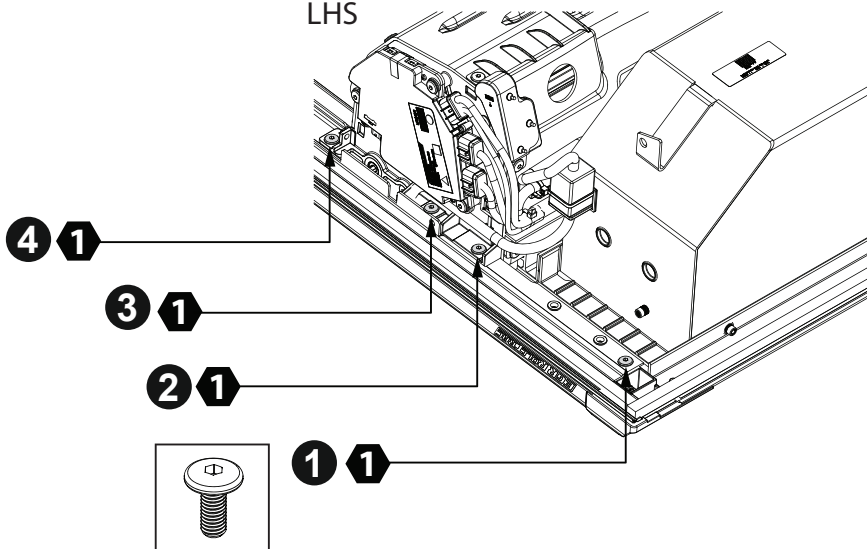

**8** Secure the Utility Box (3) to the canister with 1 screw and Torque to 5.5Nm (4ft-lb). Torque the other 3 screws to 5.5Nm (4ft-lb). Repeat for the opposite side.

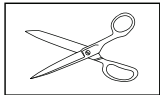

CLEAN WITH  
ALCOHOL FIRST



LHS

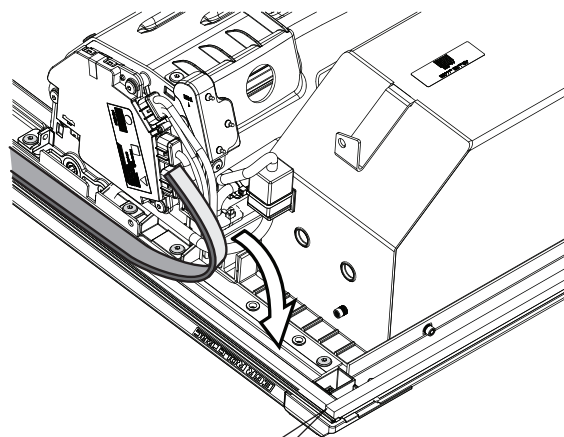

TAPES MUST CONTACT

**9** Clean powder coated surface first with alcohol spray. Trim foam tape length to ensure the end will butt against front cover seal - avoiding any gap. Peel the protective liner from the foam tape, adhere to the channel in the side rail, Press down firmly to secure. Repeat on RH side rail.

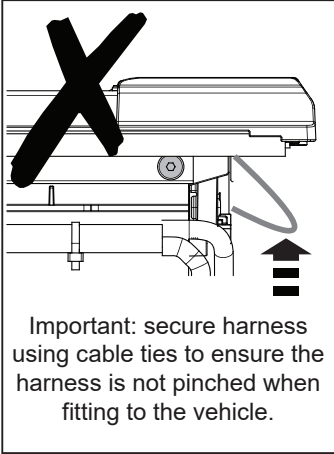

<b>CONNECT</b> ▶▶▶▶◀◀◀◀	<b>1 PUSH</b> 	<b>2 CLICK</b> 	<b>3 PULL</b> ✓ 	<b>PULL THE CONNECTOR NOT THE CABLE</b>
----------------------------	-------------------	--------------------	---------------------	---

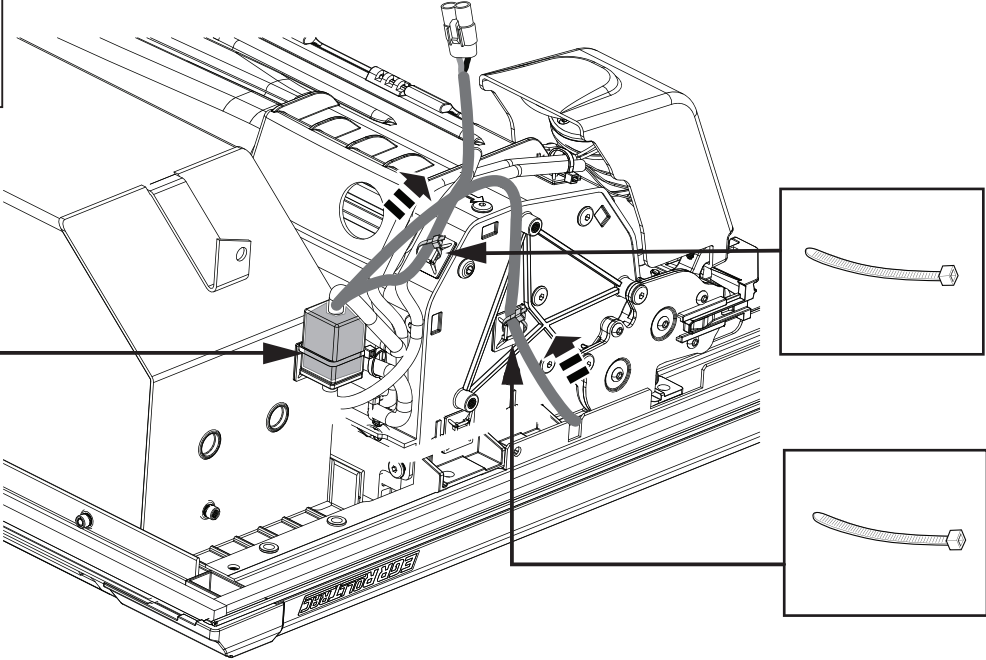

**10** Connect side rail harness connectors to the connectors on the utility box RHS. Secure the harness to the canister and utility box using cable ties at the 3 locations shown. Secure with zip ties to existing pads. Ensure all cables are retained close to the canister to prevent pinching during installation.

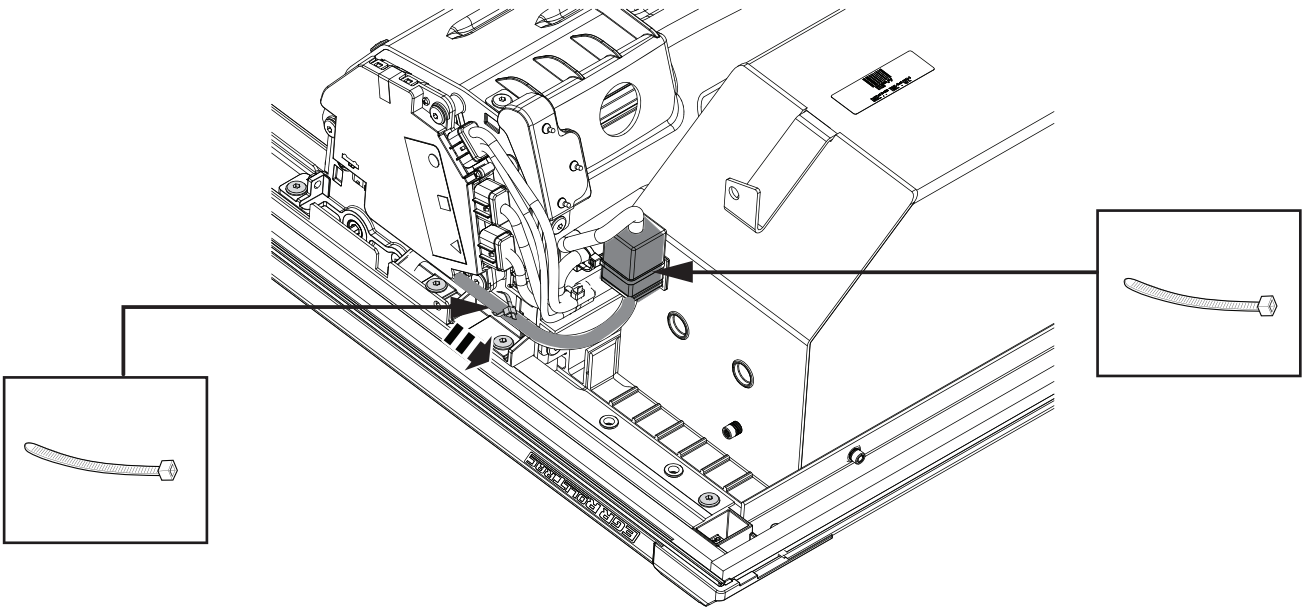

<b>CONNECT</b> ▶▶▶▶◀◀◀◀	<b>1 PUSH</b> 	<b>2 CLICK</b> 	<b>3 PULL</b> ✓ 	<b>PULL THE CONNECTOR NOT THE CABLE</b>
----------------------------	-------------------	--------------------	---------------------	---

**11** Connect side rail harness connectors to the connectors on the utility box LHS. Secure the harness to the canister and utility box using cable ties at the 2 location shown. Secure with zip ties to existing pads. Ensure all cables are retained close to the canister to prevent pinching during installation.

**CONNECT** **1 PUSH** **2 CLICK** **3 PULL** ✓ **PULL THE CONNECTOR NOT THE CABLE**

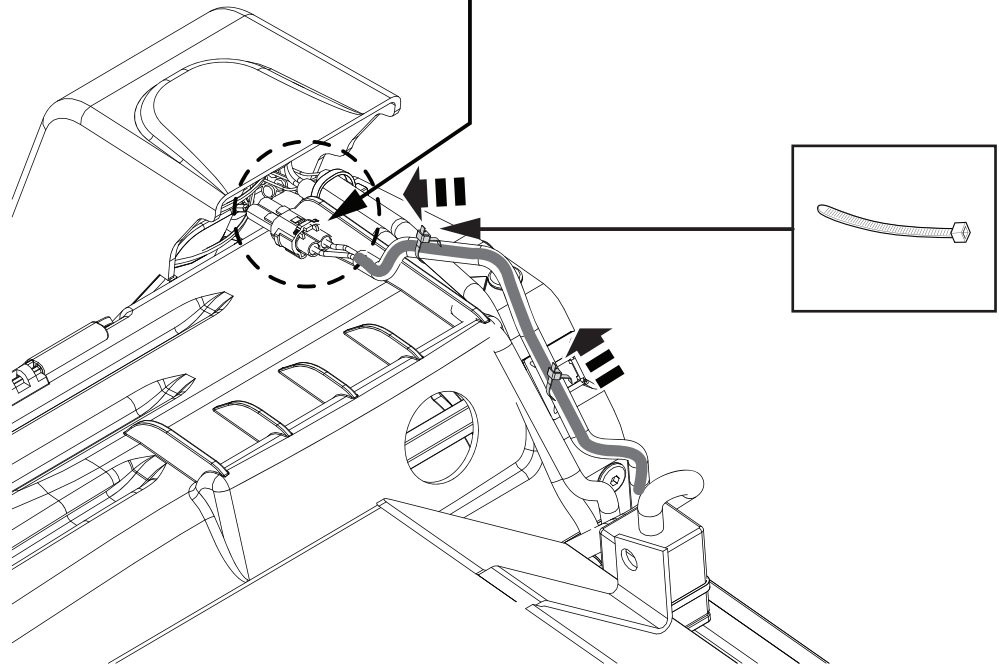

**12** Connect the lamp connector as shown next to the motor on the RHS. Secure the harness with zip tie as shown.

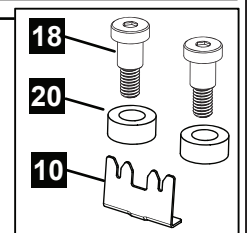
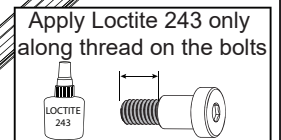
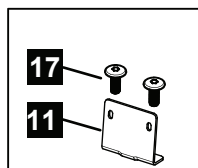
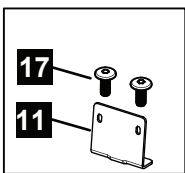
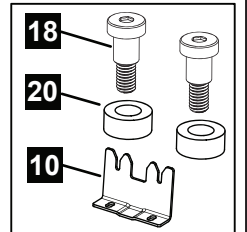
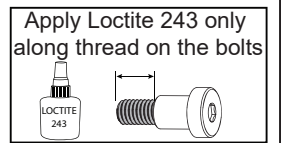
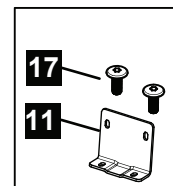
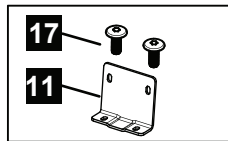
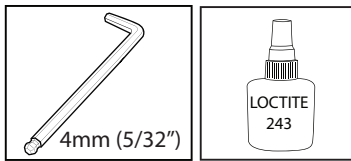

**13** Fit the two front datum brackets (10) to the side rail using the M6 shoulder bolts (18) with Loctite 243 and spacers (20). Tighten the M6 shoulder bolts (with Loctite 243), until there is still movement on datum brackets (10). Fit the mid and rear side rail brackets (11) to the side rails using the M6 screws and do not torque them.

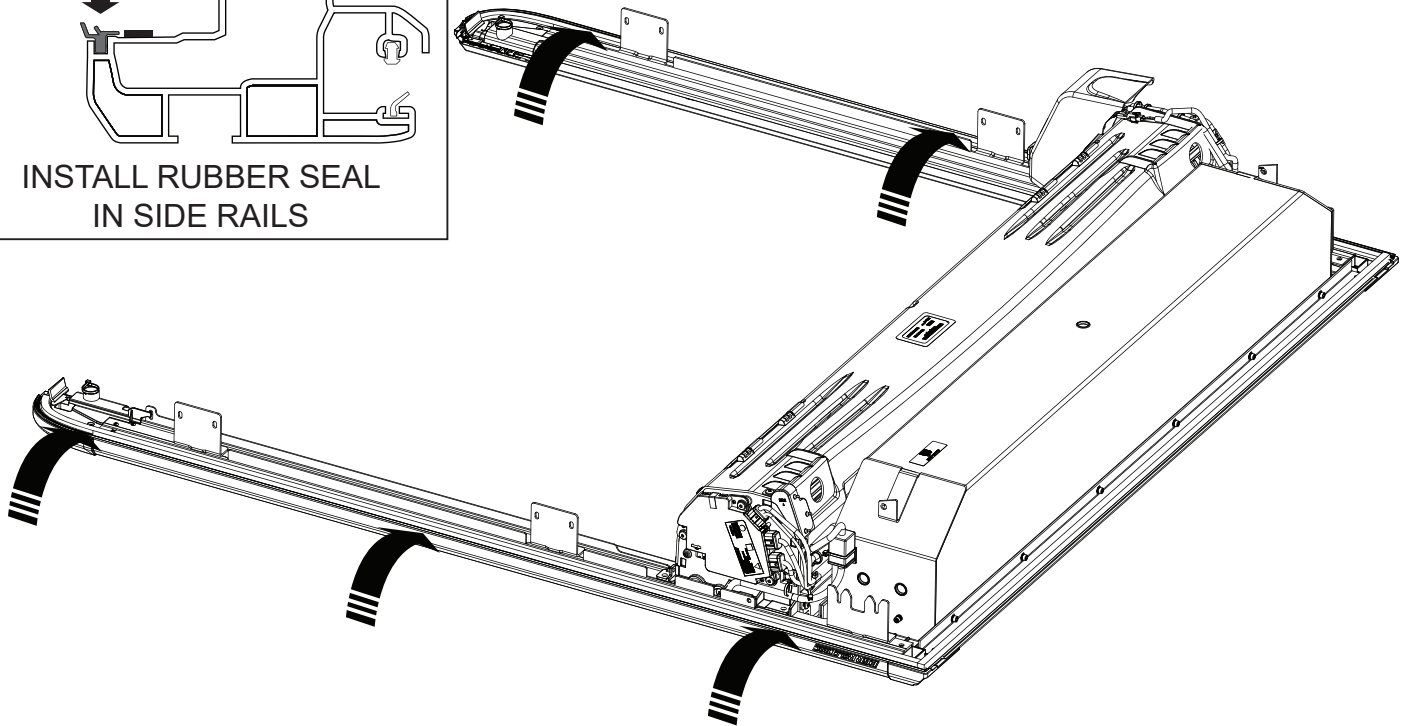
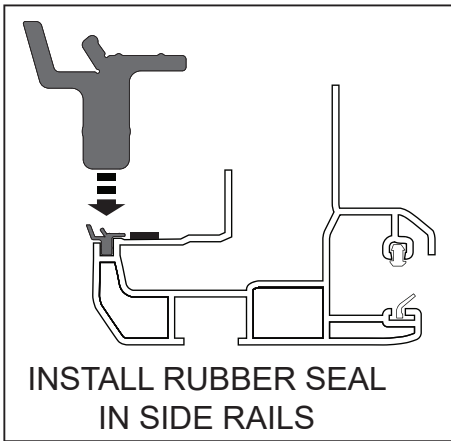

**14** Install the Rubber Perimeter Seal into each side rail and ensure seal is firmly seated (note the seal orientation).

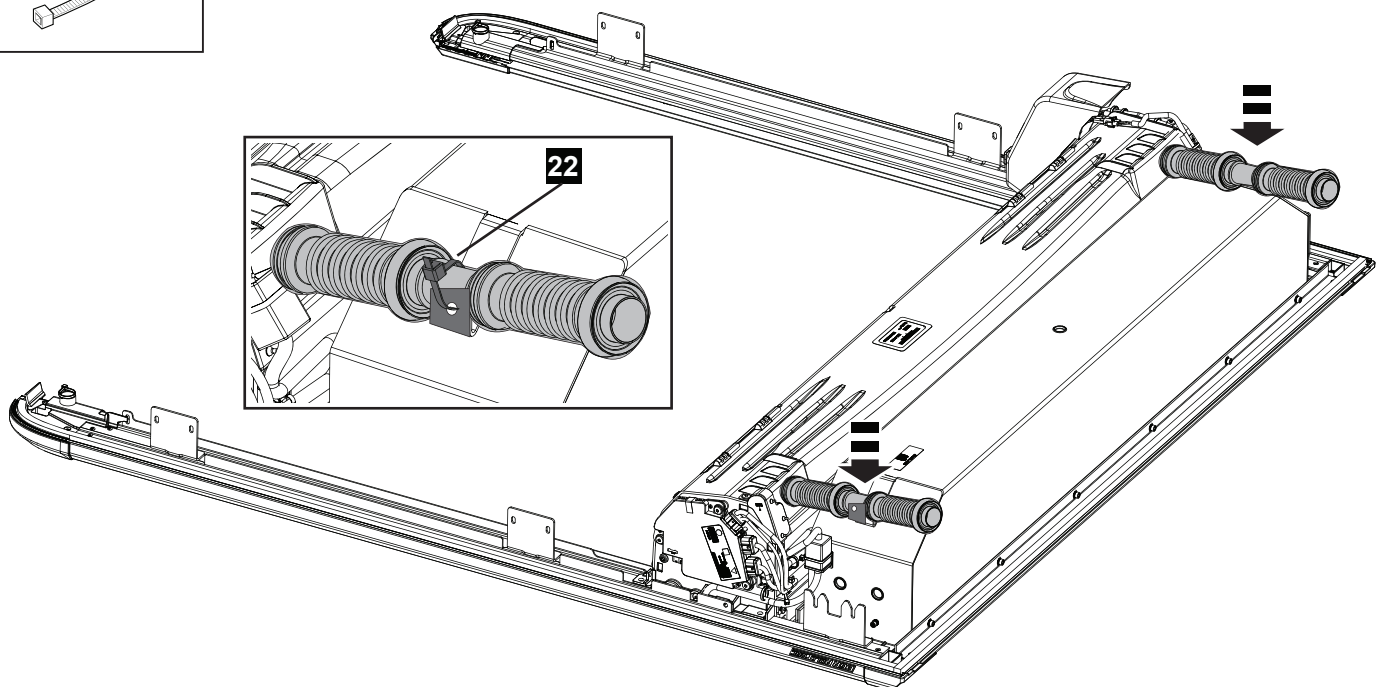
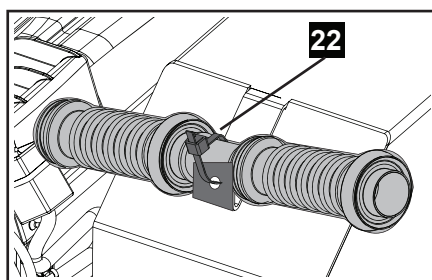
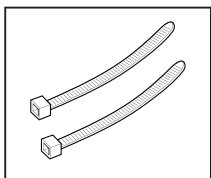

**15** Fit the front drain tubes to the canister as shown and secure with cable tie to the inside of the bracket in the Utility Box, as shown.



HEAVY

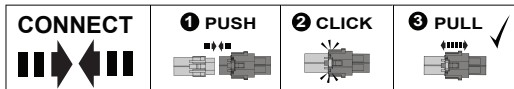
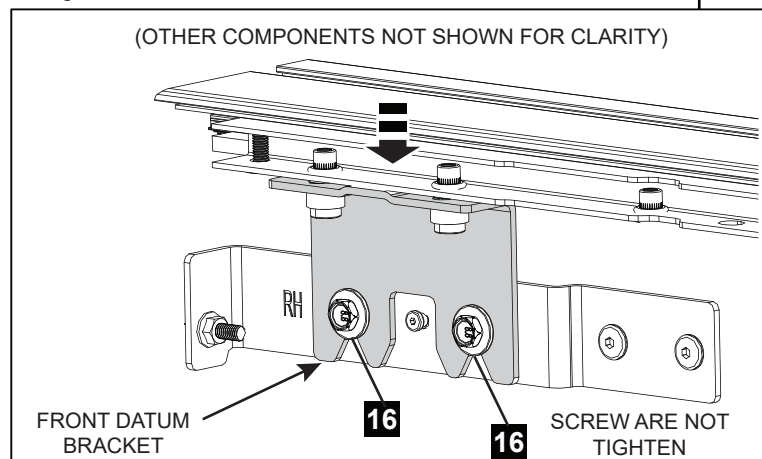
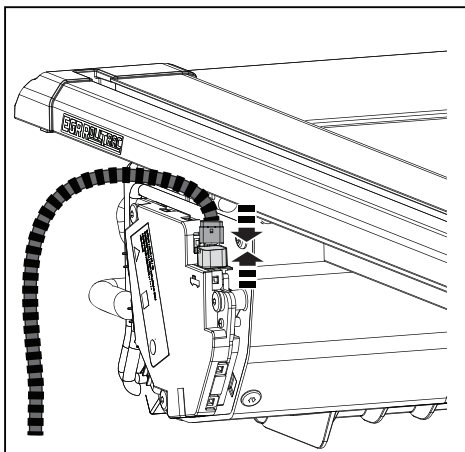
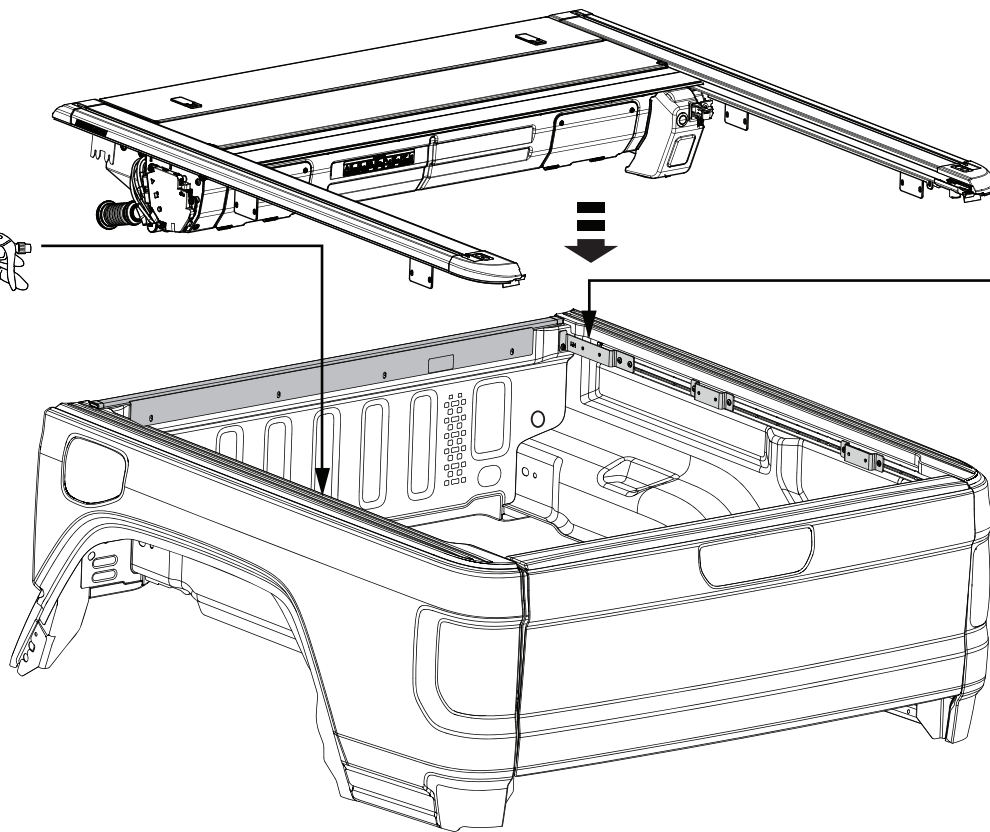

PULL THE CONNECTORS NOT THE CABLE

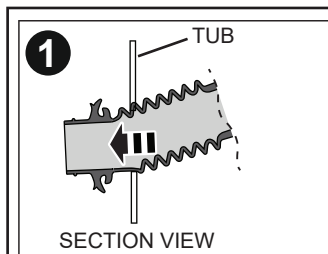

INSTALL FRONT DRAIN TUBES TO TUB

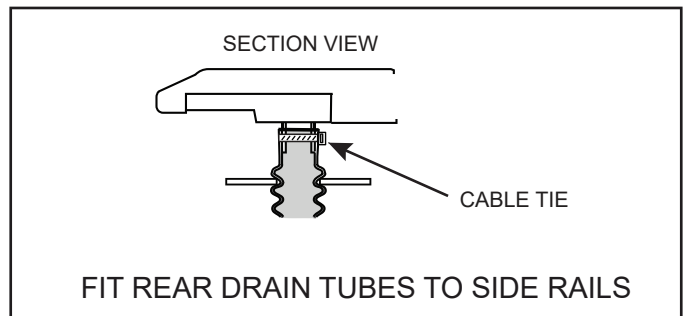
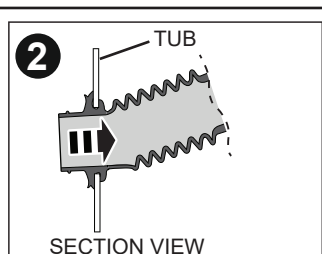

FIT REAR DRAIN TUBES TO SIDE RAILS

- 1 Spray the top surface of the tub liberally with a soapy water solution to enable the Cover to slide easily. Using two people to lift the cover from both sides and carefully lower it onto the tub. Before dropping onto the tub connect the vehicle harness to the ECU as shown. Drop the RollTrac straight onto tub. Connect the front drain tubes to the tub. Connect the rear drain tubes and secure with cable ties. Ensure front datum brackets are correctly aligned with the bolts.

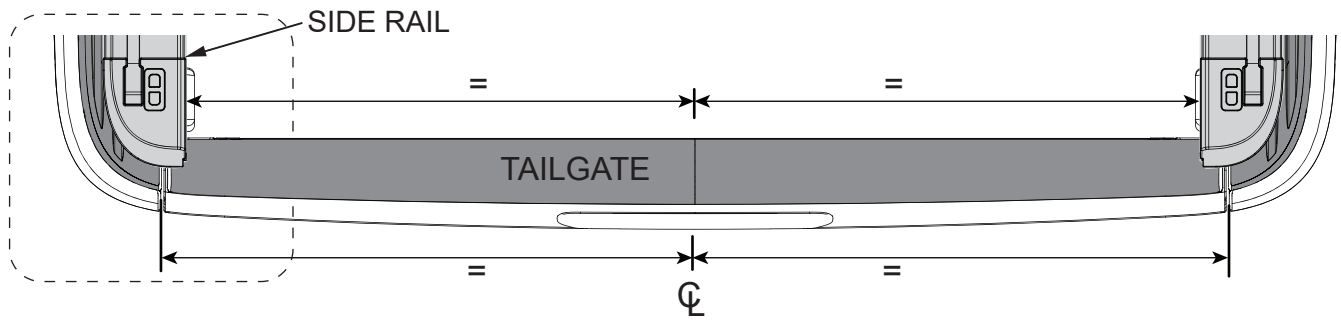

CENTRALISE AND ALIGN THE COVER TO THE MARKINGS

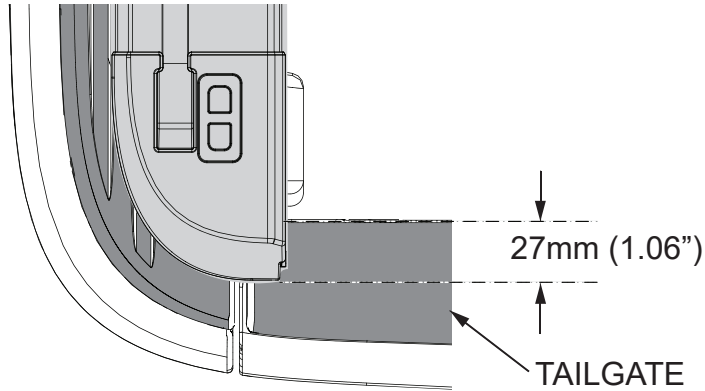

COVER POSITION REARWARDS

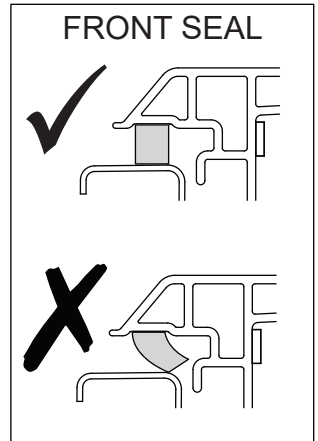

**2** Apply masking tape at the centre of the tailgate. Measure the distance between the rear corners of the tub and draw a centre line on the masking tape. Measure the distance from the marked centre line to both rear corners of the RollTrac and ensure it is equally distanced.

Adjust the cover so that it is aligned with the markings as shown. Ensure seals are not deformed by lifting cover and dropping vertically on tub.

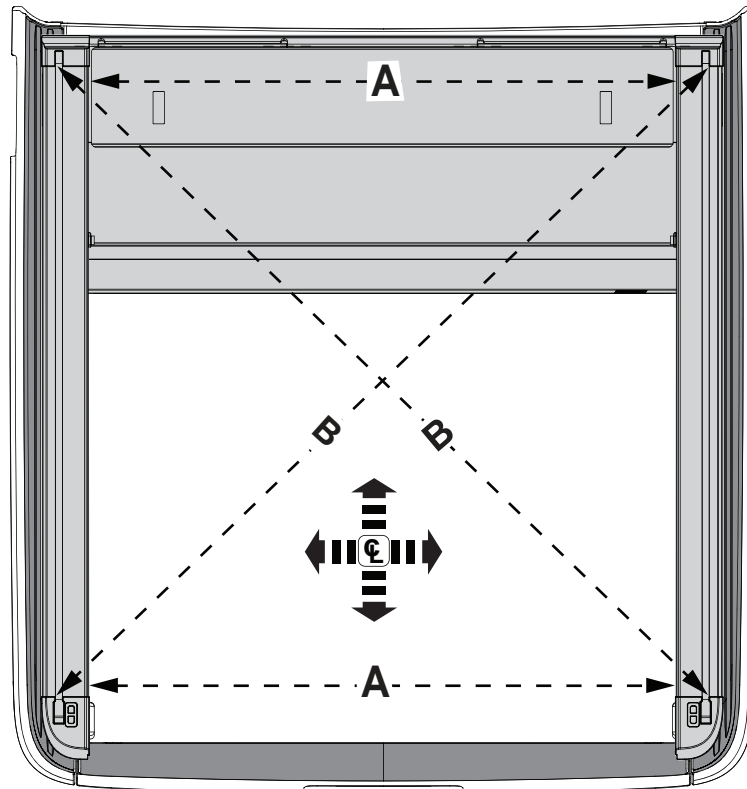

**A = A    B = B**

**PERFORM FITMENT CHECK**

**3** Perform diagonal fitment check.



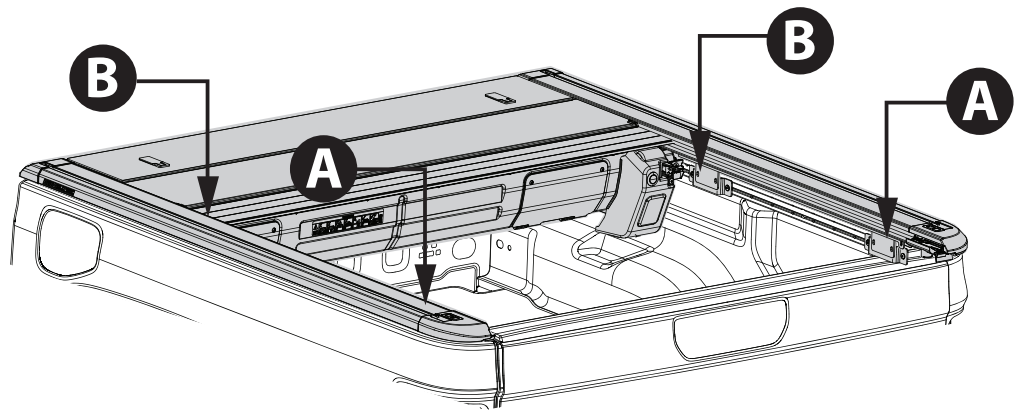
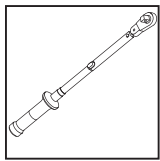
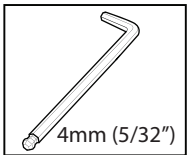

**1** 5.5Nm  
4ft-lb

VIEW UNDER THE BASE RAIL RHS

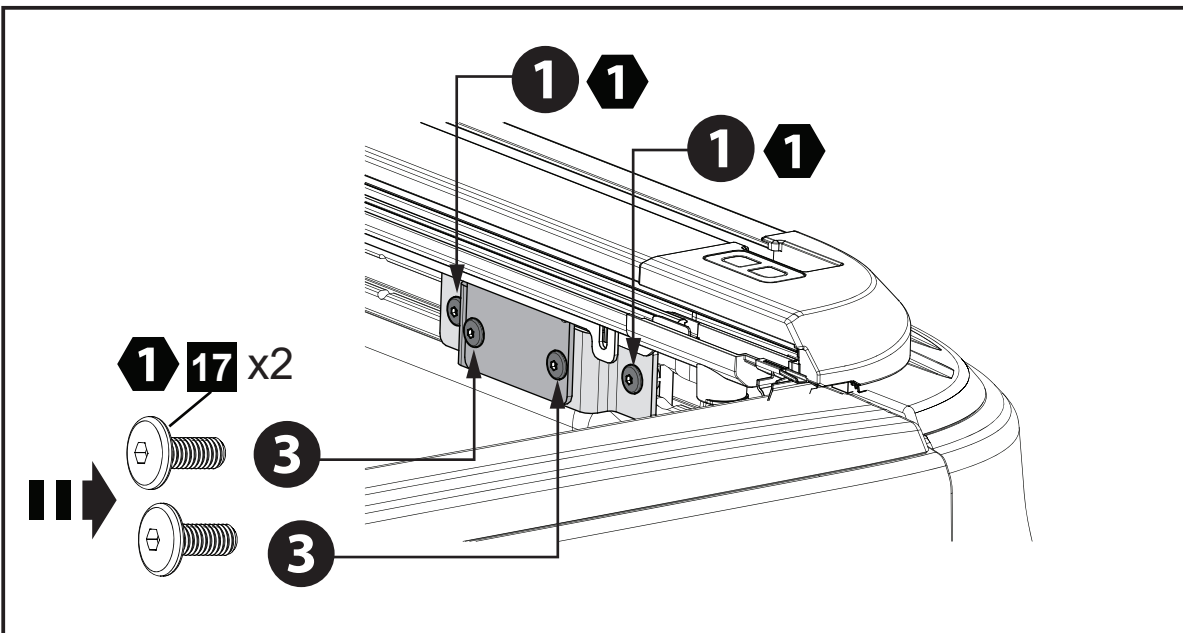
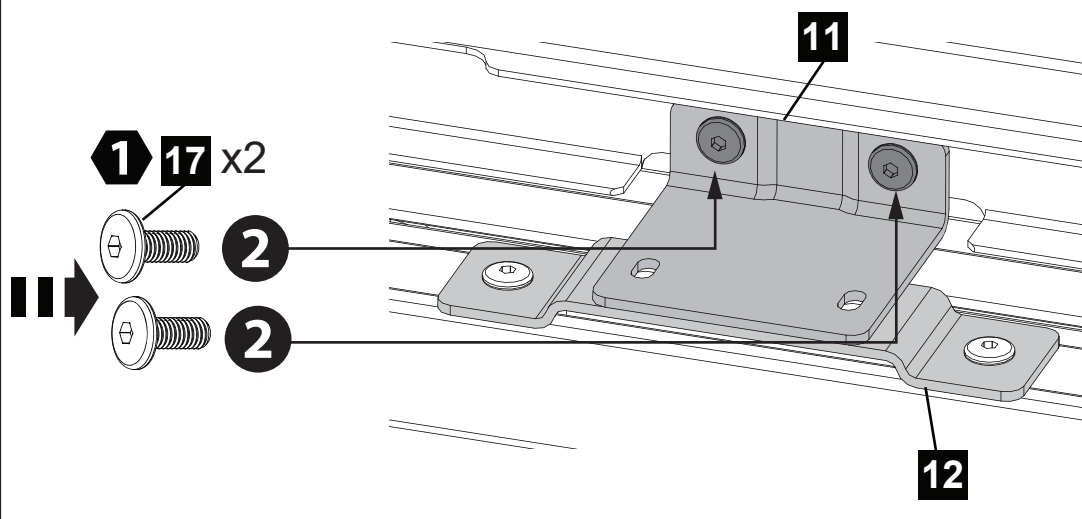

- 4** Fit the side rail brackets (11) to the base rails with two screws (17) as shown in top detail. Secure the Rolltrac side rail brackets (11) to the mounting brackets (12). Torque the screws following the sequence in the detail. Work from right to left as shown (AA & BB) to balance the load.

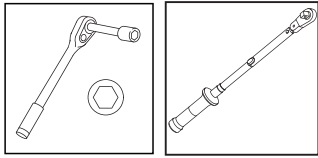

**1** 5.5Nm  
4ft-lb

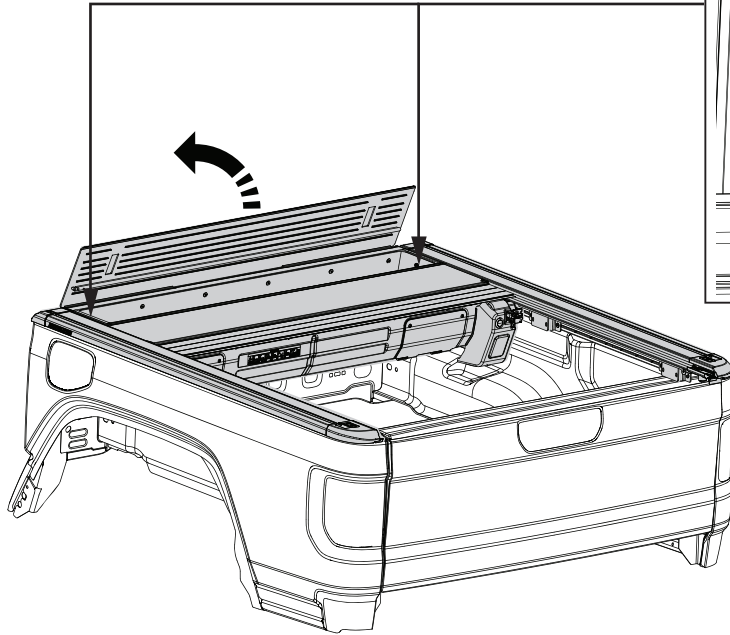
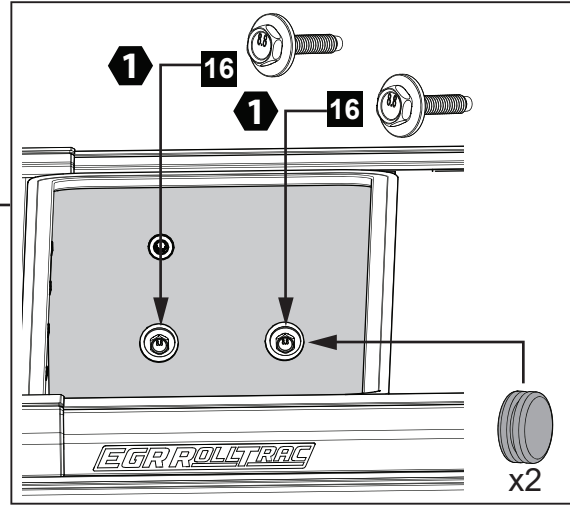

- 5** Secure the Rolltrac datum brackets (front) to the tub mounting brackets with two pre fitted M6 screws. Note: to access the screws, open the Utility Box and use the hole to insert the socket spanner. Torque the tub brackets bolts to 5.5Nm (4ft-lb). Cover holes with rubber grommets as shown.

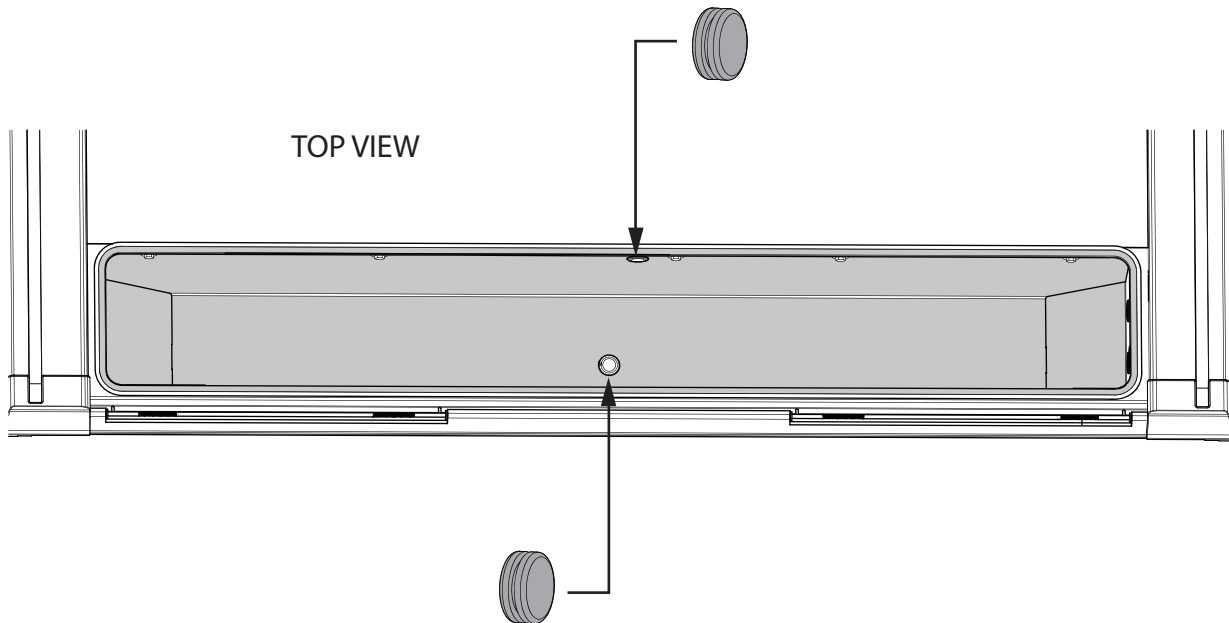

- 6** Cover holes with rubber grommets as shown and inspect if all rubber grommets are fitted.

**SILICONE LUBRICATION TO THE SPIRALS**  
(MODELS MAY VARY, IMAGES FOR REFERENCE ONLY)

**1** Open tailgate and EGR RollTrac

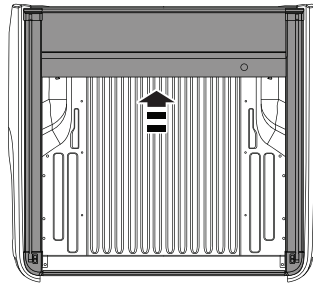
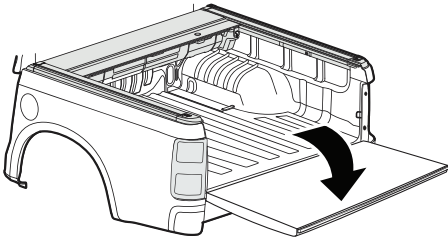

**TOOLS REQUIRED:**

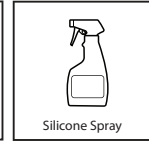
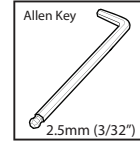

**2** Using a 2.5mm Allen Key remove the 4 screws and open the inspection covers.  
**WARNING:** Keep clear of moving parts and avoid unnecessary operation of the EGR RollTrac while inspection covers are open.

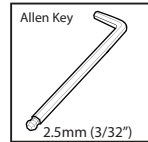
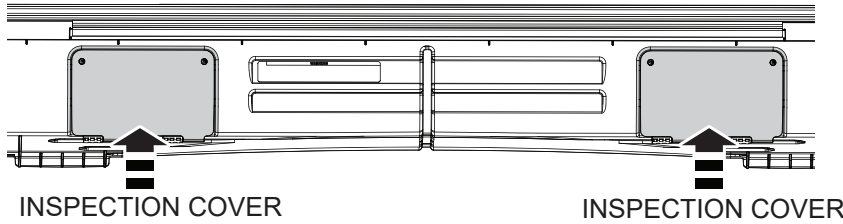

**3** Close the EGR RollTrac to access canister internals

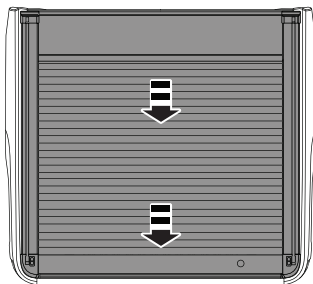

**4** To avoid water leaks, look into the inspection points and check that the flanges of both front drain tubes are correctly engaged to the canister cover (without any kinking etc.), readjust if required.

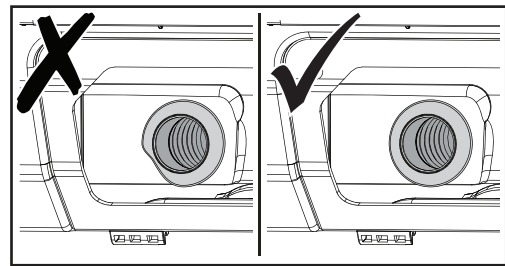

**5** Using plastic compatible 100% Silicone Spray (ONLY) spray onto the spirals on both ends of the canister through the inspection points.

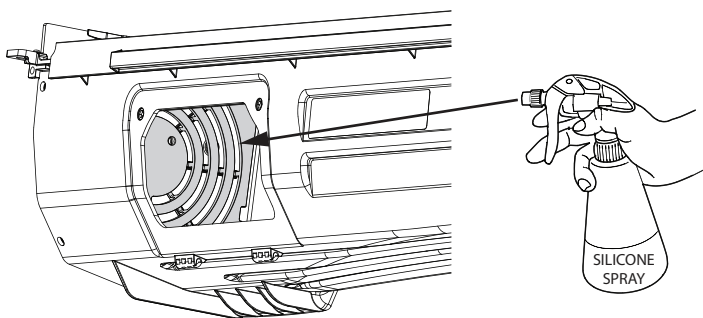

**6** Open the EGR RollTrac

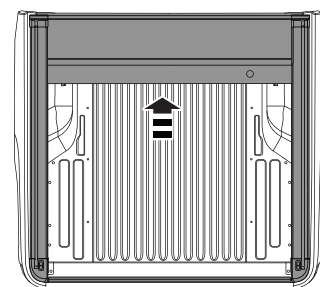

**7** Close the inspection covers and secure with retained screws. Open and close the EGR RollTrac to distribute lubricant and check operation.

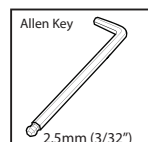
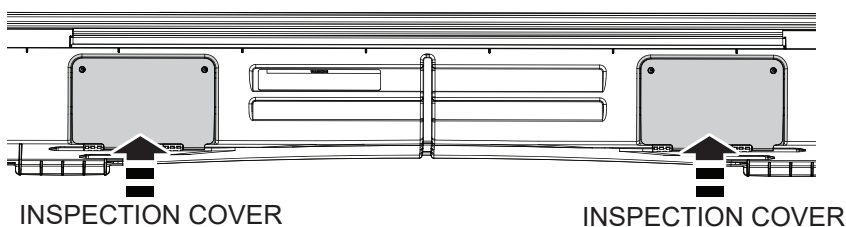

1. Insert fuse to EGR RollTrac harness.
2. Make sure the tailgate is closed.
3. Engage motor, pull out lever (clutch).
4. Make sure the vehicle is unlocked and driver door open.
5. Press both buttons and hold for 5 sec. until light illuminates.



**WARNING:** Keep obstructions clear of cover during calibration mode.

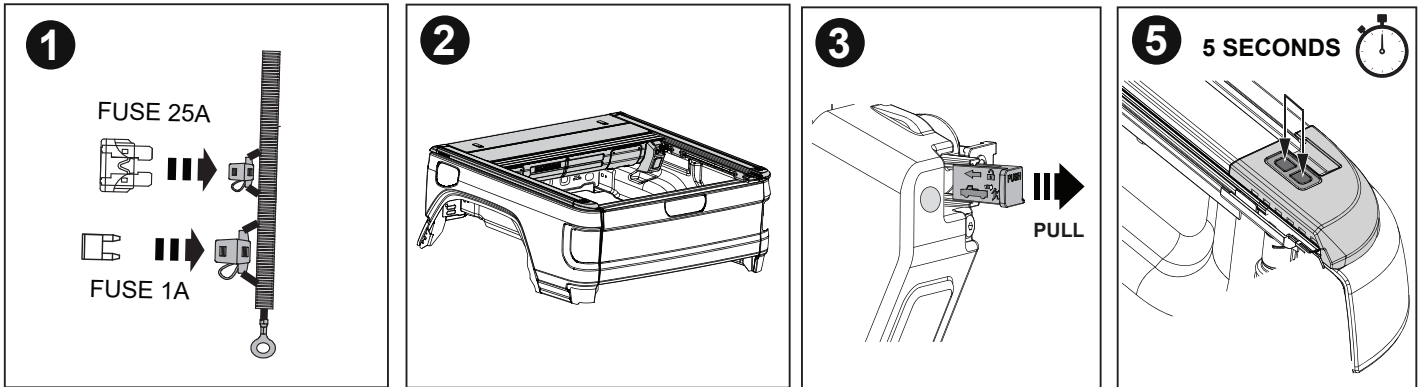

- Cover will CLOSE and OPEN once automatically.
- The EGR RollTrac internal LED light will pulse slowly during calibration and stop pulsing when calibration is complete.

START OF CALIBRATION

1

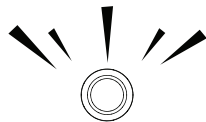
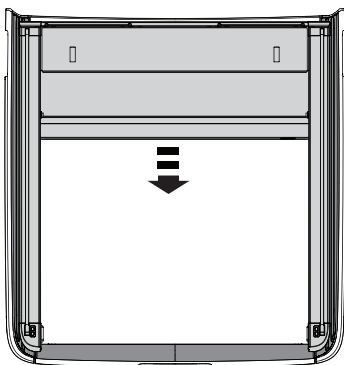

2 SECOND PULSE  
DURING CALIBRATION

2

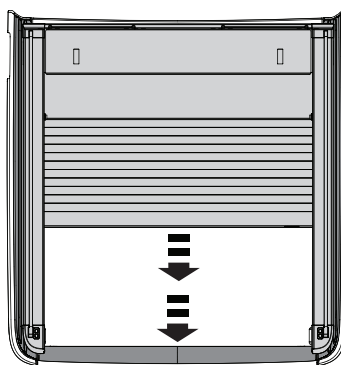

3

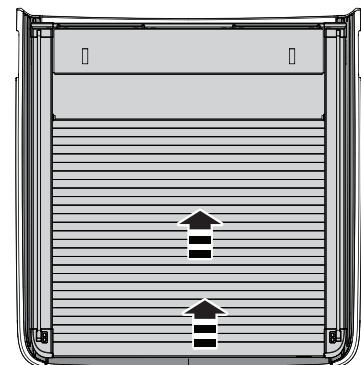

END OF CALIBRATION

## OPENING AND CLOSING PROCEDURE

### Electric Opening Procedure:

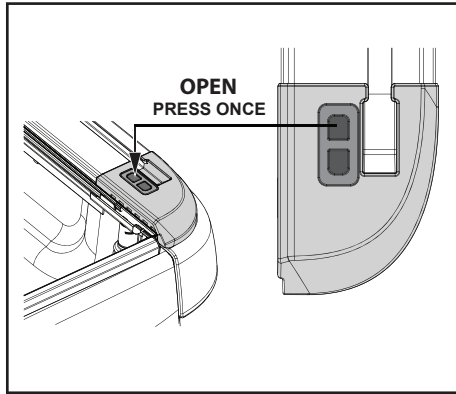
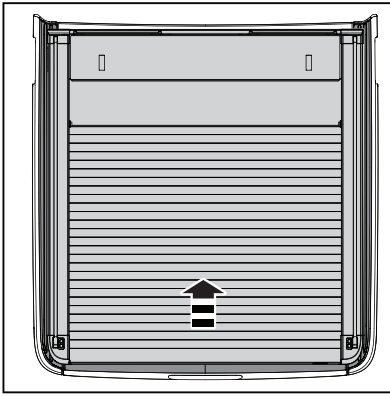

1. Press the front button on the EGR RollTrac side rail as shown.

### Electric Closing Procedure:

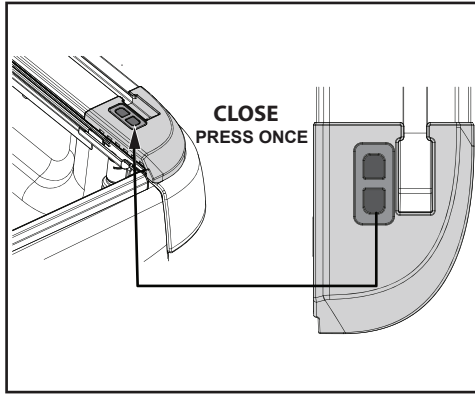
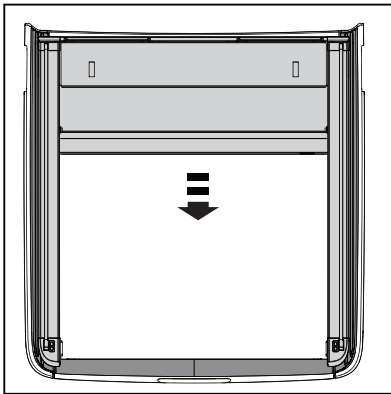

1. Press the rear button on the EGR RollTrac side rail as shown.

NOTE: EGR RollTrac should open and close smoothly. If cover does not lock or open correctly, please refer to the trouble shooting section in the Owners Manual. If the EGR RollTrac closing is slow, clean the siderails and ensure that no dirt or debris is inside the drive rail.

### Manual Opening and Closing Procedure:

Locate the Clutch Disengagement Lever on the RH side of the cover and push the Clutch inward to disengage the motor. Pull the cover rearward or forward as required. Before driving vehicle ensure you re-engage the clutch.

**IMPORTANT:** If clutch was disengaged, calibration procedure needs to be re-run prior to electric operation.

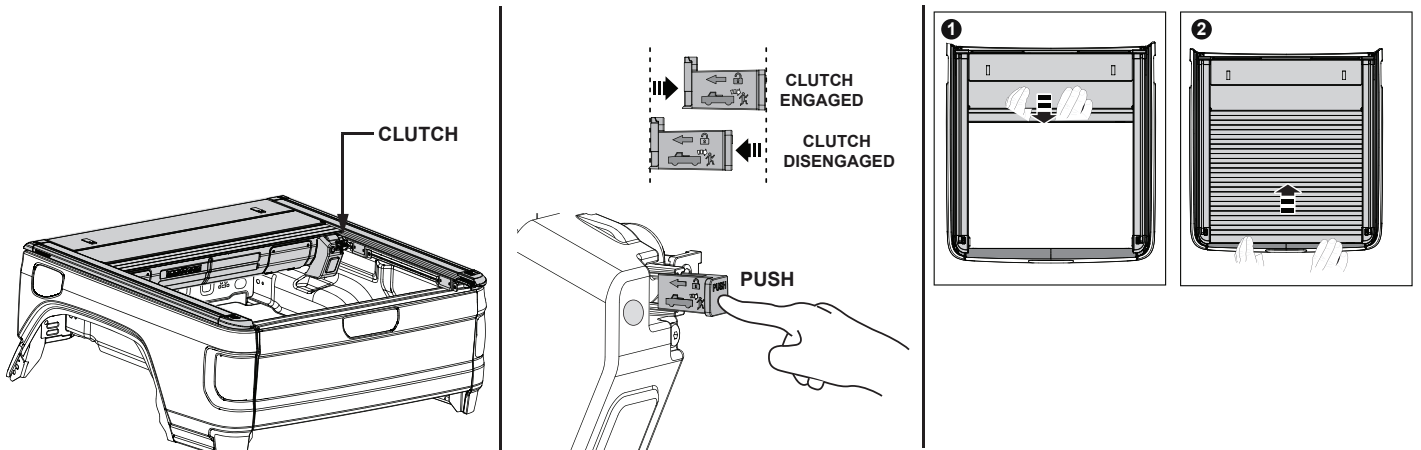

# KEY FOB OPERATION

**IMPORTANT:** We recommend that you program your key fob to lock and unlock all doors using one click only. This function can be set on your infotainment screen using the vehicle system control function/setup:

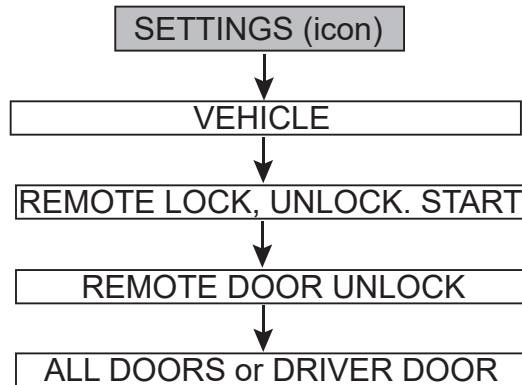

## LOCKING / AUTO CLOSE PROCEDURE

### Key Fob

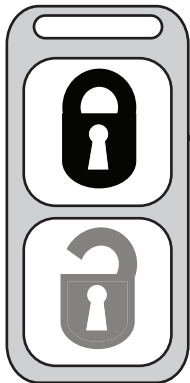

1. Press lock twice within 2 second, the vehicle will lock, if closed the RollTrac will lock, if open it will auto close.
2. To pause while in auto close motion, press lock once and the RollTrac will stop.
3. To resume auto close, press lock twice within 2 second.
4. When auto close is complete the RollTrac will auto lock.

## UNLOCKING / AUTO OPEN PROCEDURE

### Key Fob

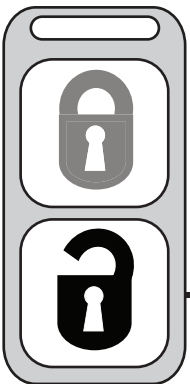

1. Press unlock twice within 2 second, the vehicle will unlock and the RollTrac will auto open.
2. To pause while in auto open motion, press unlock button once and the RollTrac will stop.
3. To resume auto open, press unlock twice within 2 second.
4. When auto open is complete the RollTrac will remain open until operated by either the key fob or the RollTrac buttons.

## NOTES

- If pause is activated by the fob whilst auto closing, the RollTrac can be closed and paused using the RollTrac close button. Reactivate both Rolltrac buttons by unlocking the vehicle.
- If the RollTrac is open and the lock button is only pressed once, the vehicle and the RollTrac will lock.